

Alu Line 100

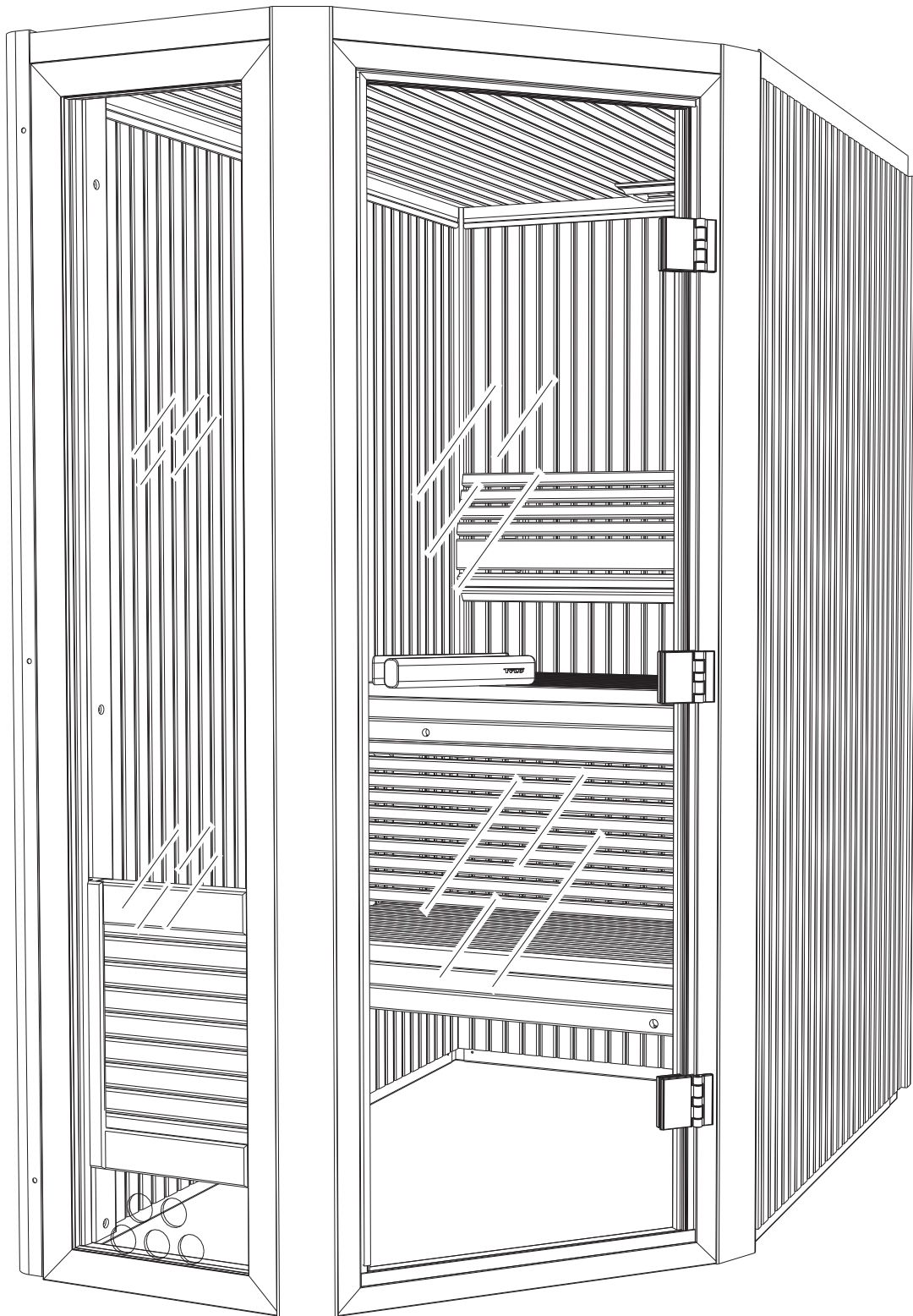

Basturummets layout och i vilken ordning väggarna skall monteras. Denna anvisning visar monteringen av layout 1.
The layout of the sauna room and in which order the wall sections are to be assembled. This instruction shows the installation of layout 1.

Grundriss des Saunaraums und die Reihenfolge, in der die Wände aufgestellt werden sollen.

Configuration de la cabine de sauna et ordre de montage des cloisons.

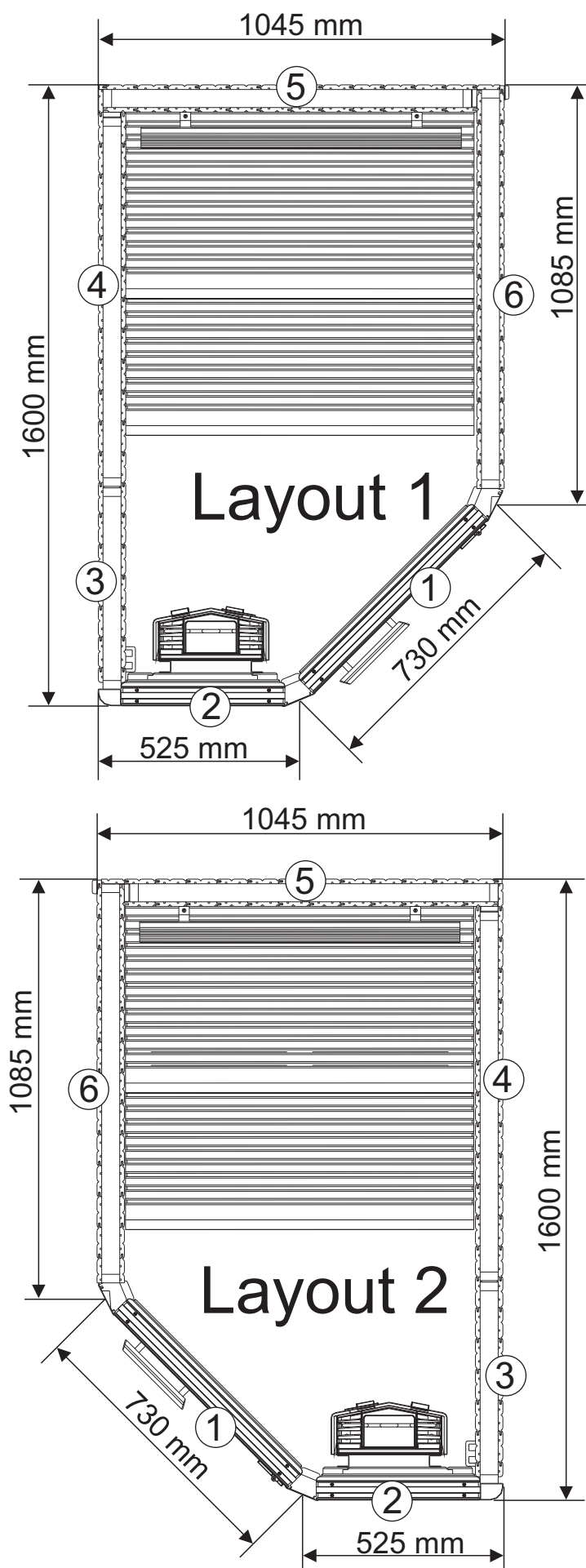

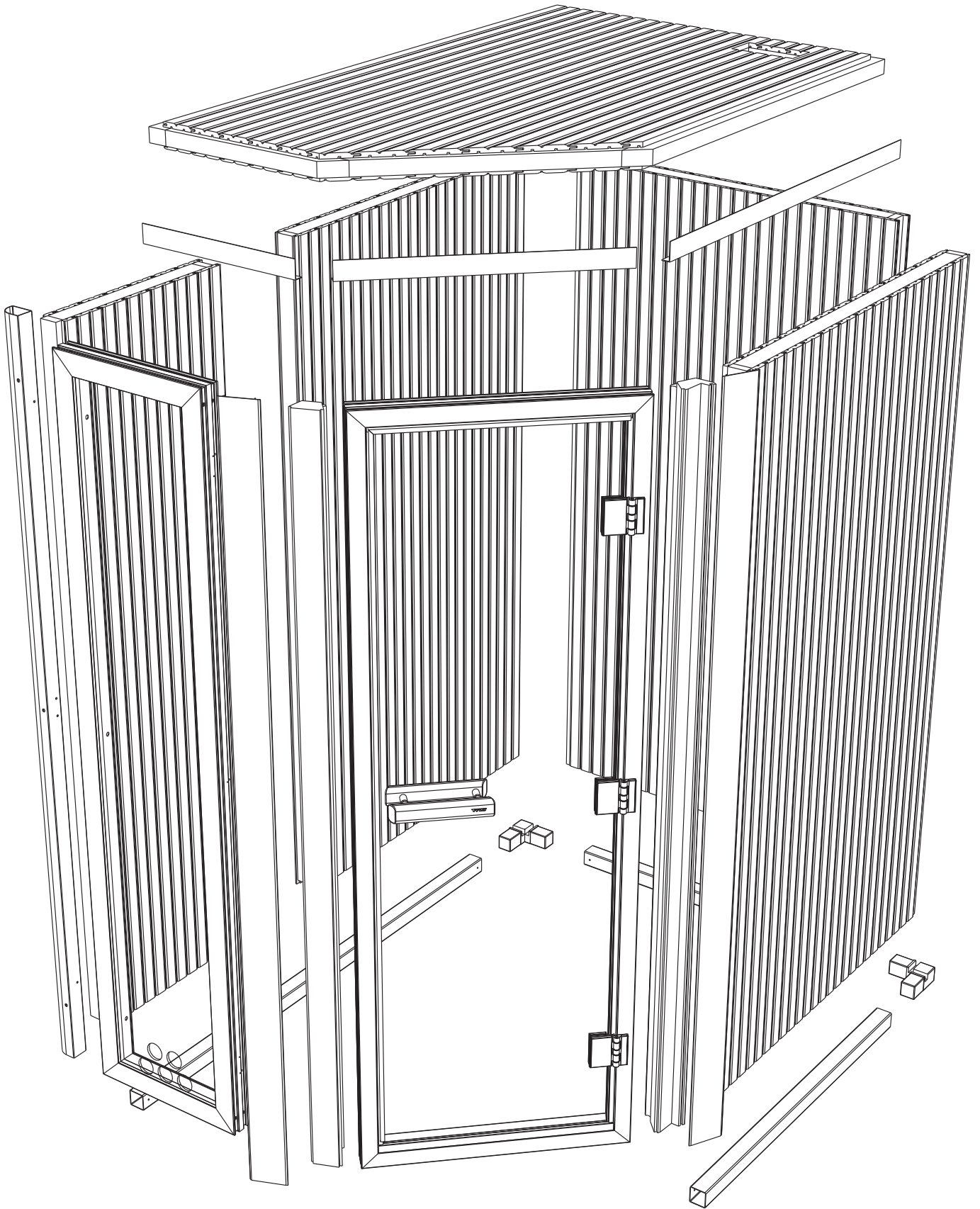

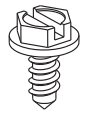

9.5mm

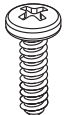

13mm

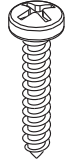

22mm

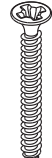

25mm

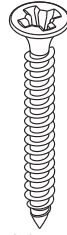

30mm

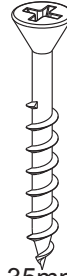

35mm

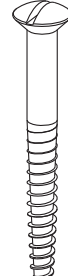

40mm

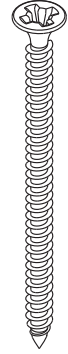

60mm



30mm



30mm

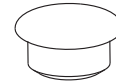
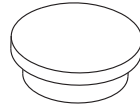
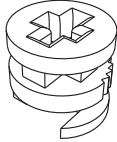

- 1** Dörren kan monteras höger- eller vänsterhängd.
 The door can be hung with the hinges on the right or on the left.
 Die Tür kann links- oder rechtsöffnend eingebaut werden.
 La porte peut ouvrir à gauche ou à droite.

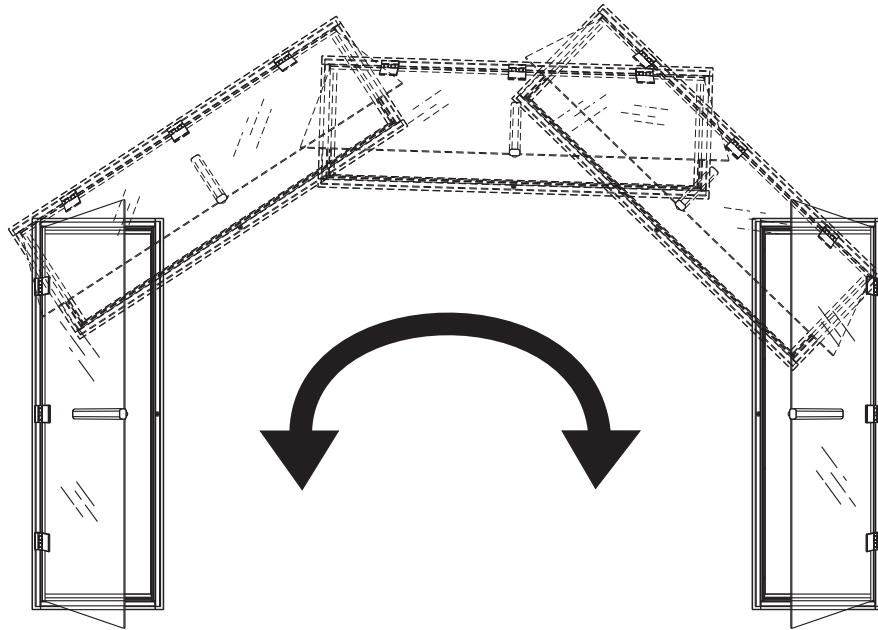

Vänsterhängd
 Left hinged
 Scharniere links
 Charnières à gauche

Högerhängd
 Right hinged
 Scharniere rechts
 Charnières à droite

Vid justering av dörr i höjled eller sidled, lossa skruvarna som går igenom gångjärn och glas.
 Vid justering i djupled, lossa det eller de gångjärn som behöver justeras och lägg erforderligt antal utfyllnadspackningar (bild 3) mellan gångjärn och aluminiumkarm.

To adjust the door sideways or vertically, slacken off the screws holding the hinges to the door glass.
 To adjust for abutment against the frame, release the hinge(s) requiring adjustment, and place the necessary number of packing plates (see sketch 3) between the hinge(s) and the aluminium door frame.

Zum seitlichen oder senkrechten Einstellen der Türe die Schrauben, die durch die Scharniere und das Türglas gehen, etwas aufdrehen.
 Zur Tiefeneinstellung das jeweilige Scharnier so weit abschrauben, daß die erforderliche Anzahl von Ausgleichblechen (siehe Abbildung 3) zwischen das Scharnier und den Aluminiumrahmen eingelegt werden kann.

Si la porte requiert un réglage vertical ou horizontal, déposer les vis des paumelles.
 Pour régler la porte en profondeur, desserrer la ou les paumelles requérant une modification et placer (figure 3) le nombre de cales requis entre paumelle et chambranle.

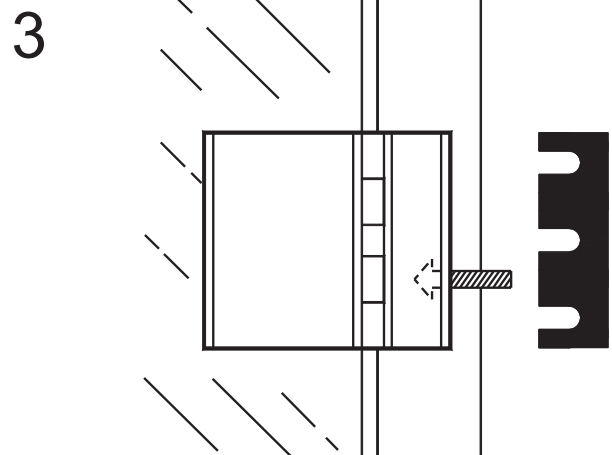
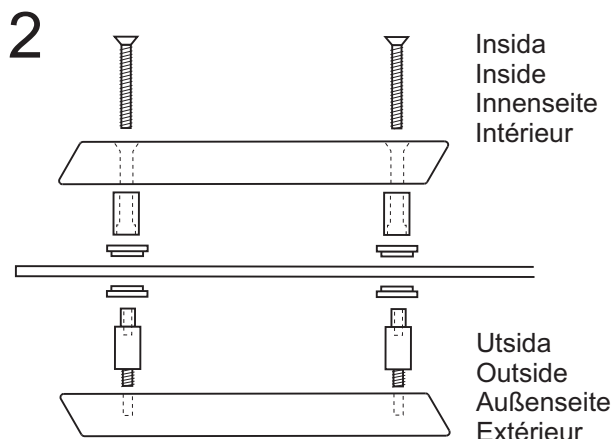

4

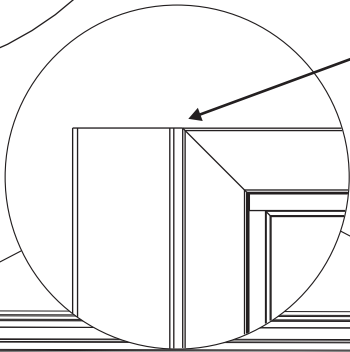
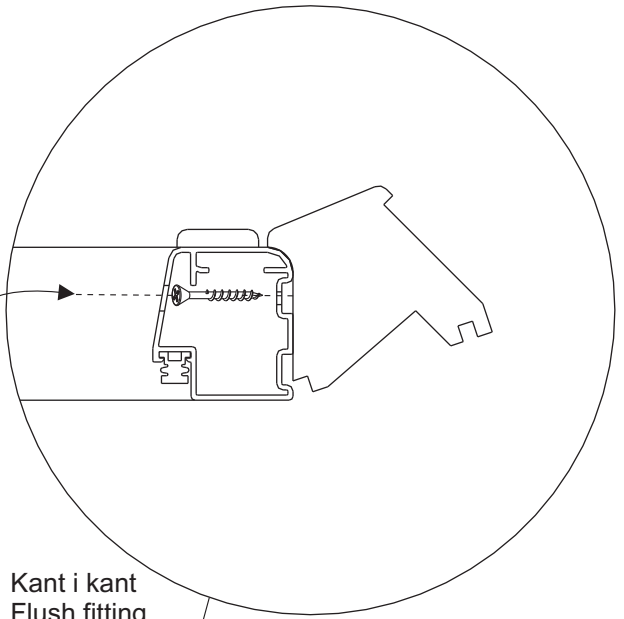
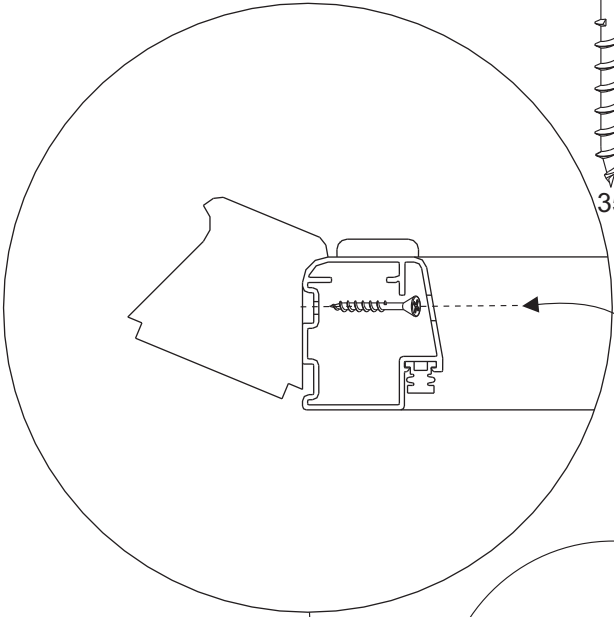
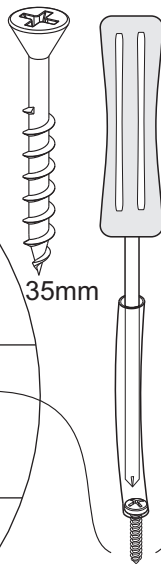

Kant i kant
Flush fitting
Kantenbündig
Bord à bord

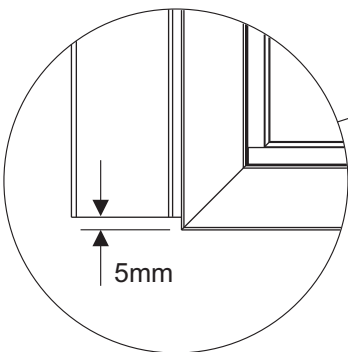
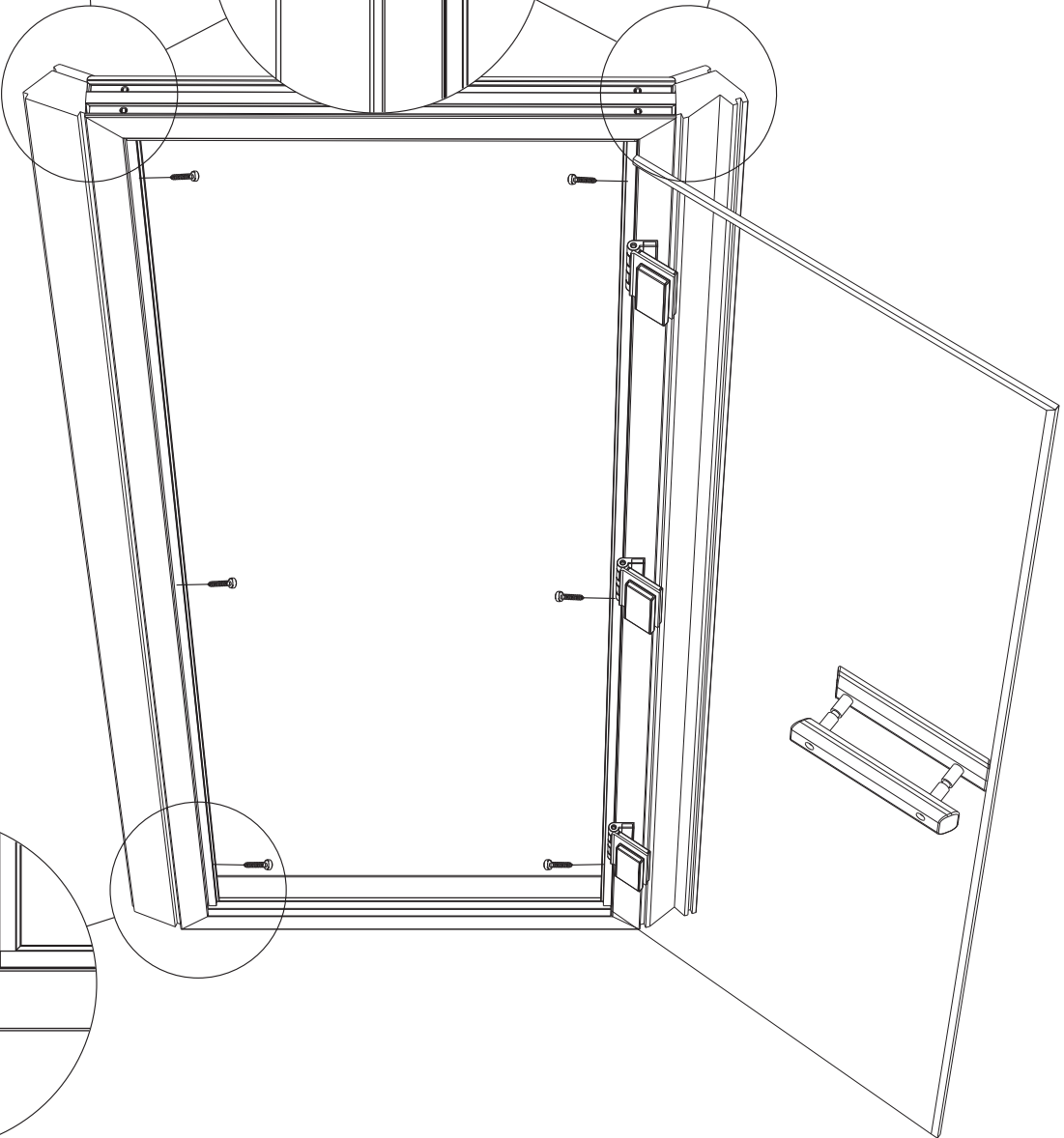

6

5

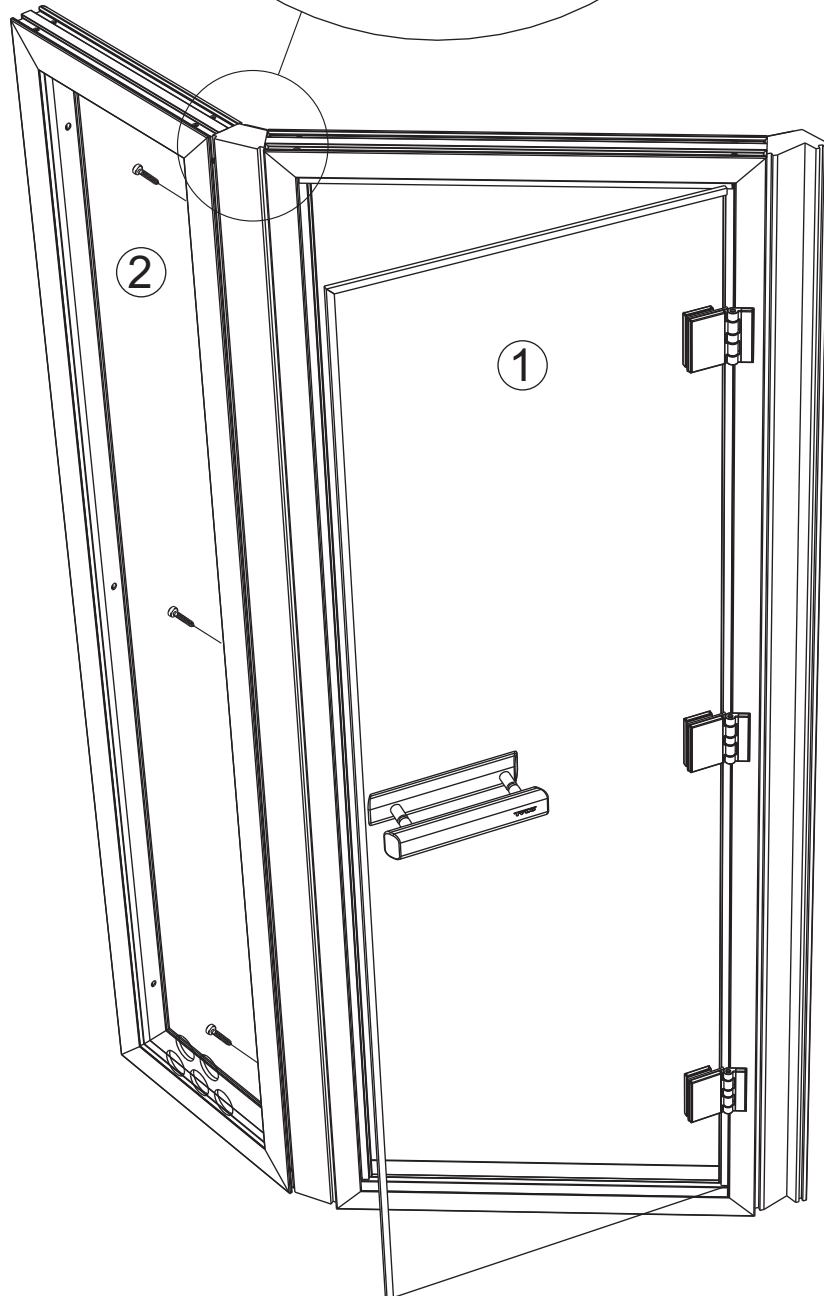
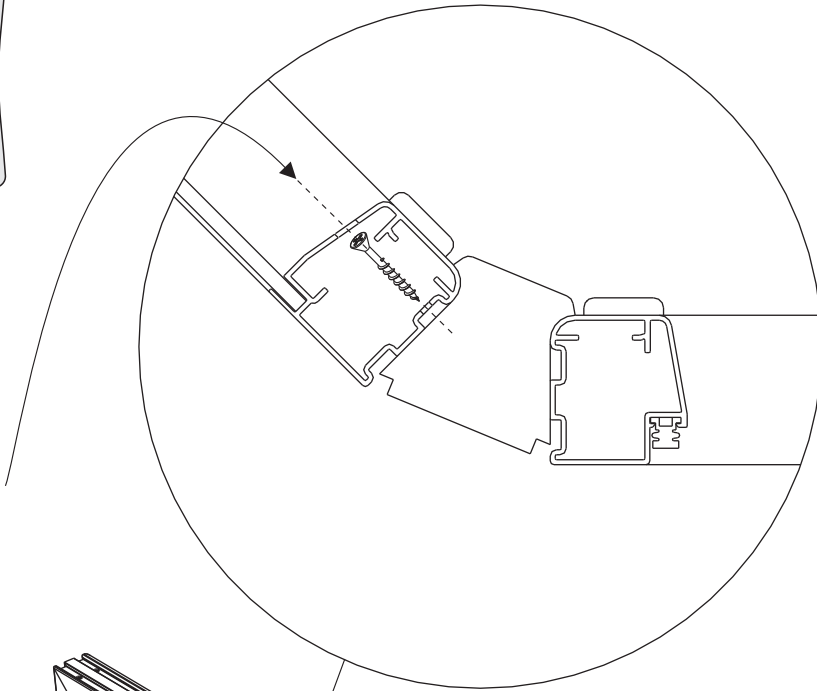
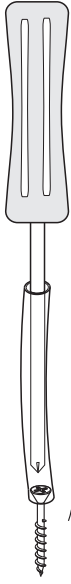
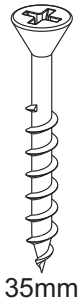

6

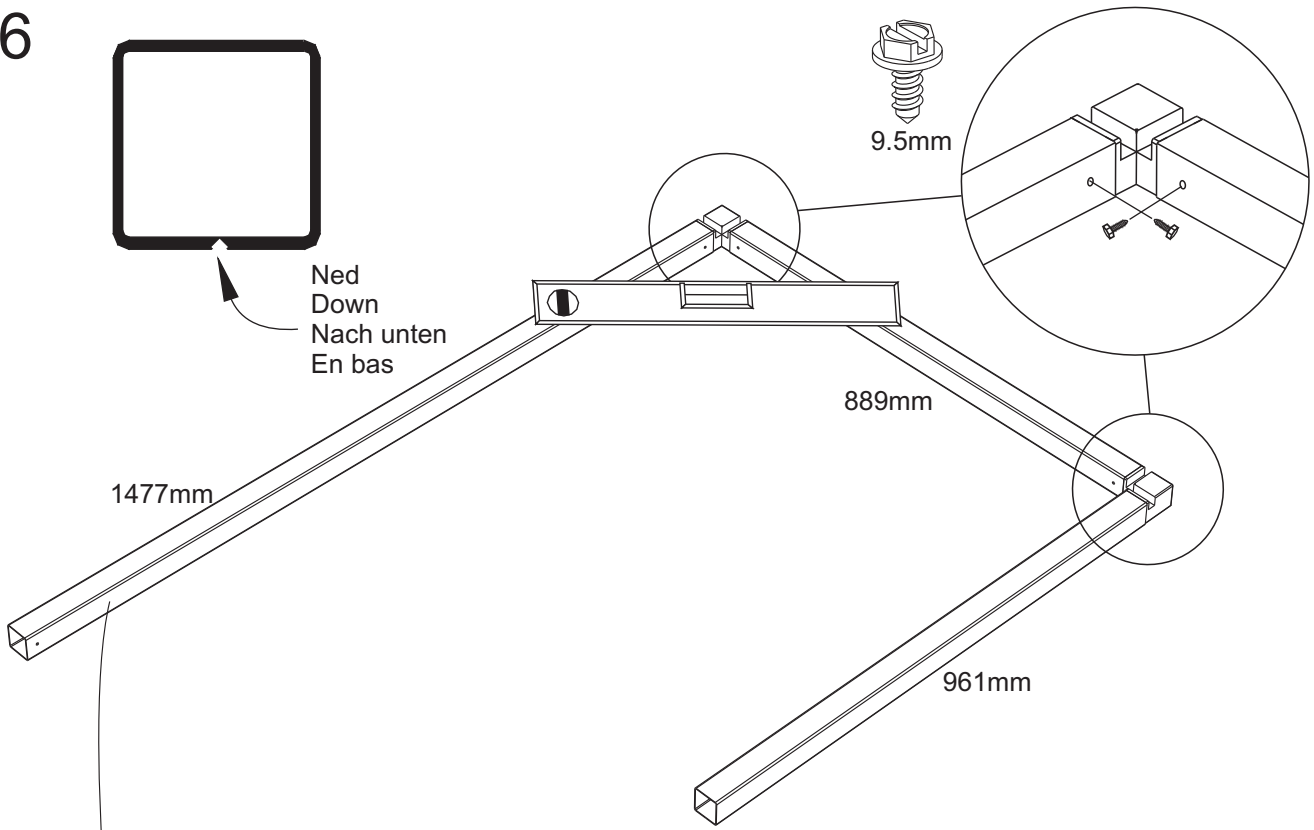

7

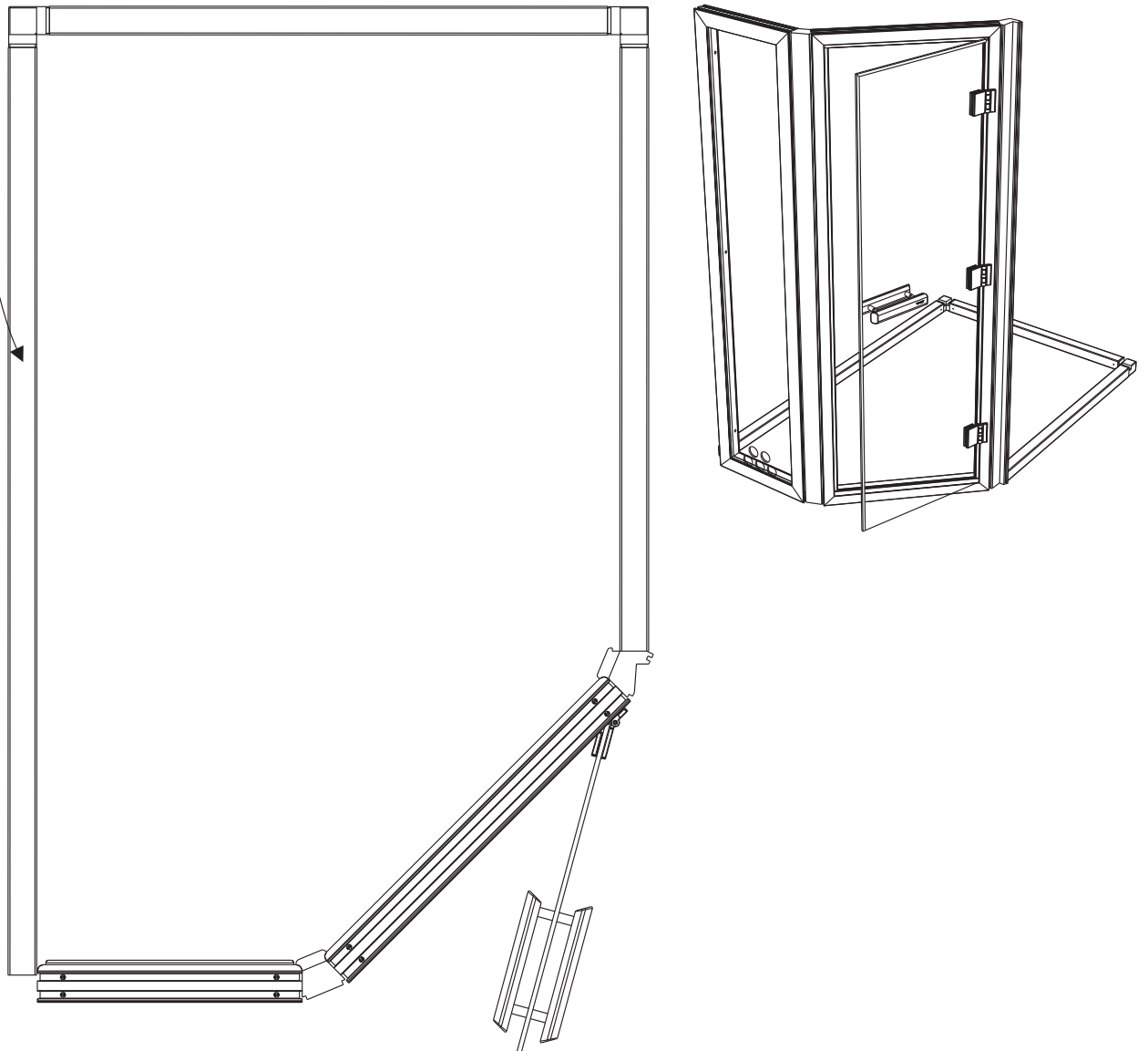

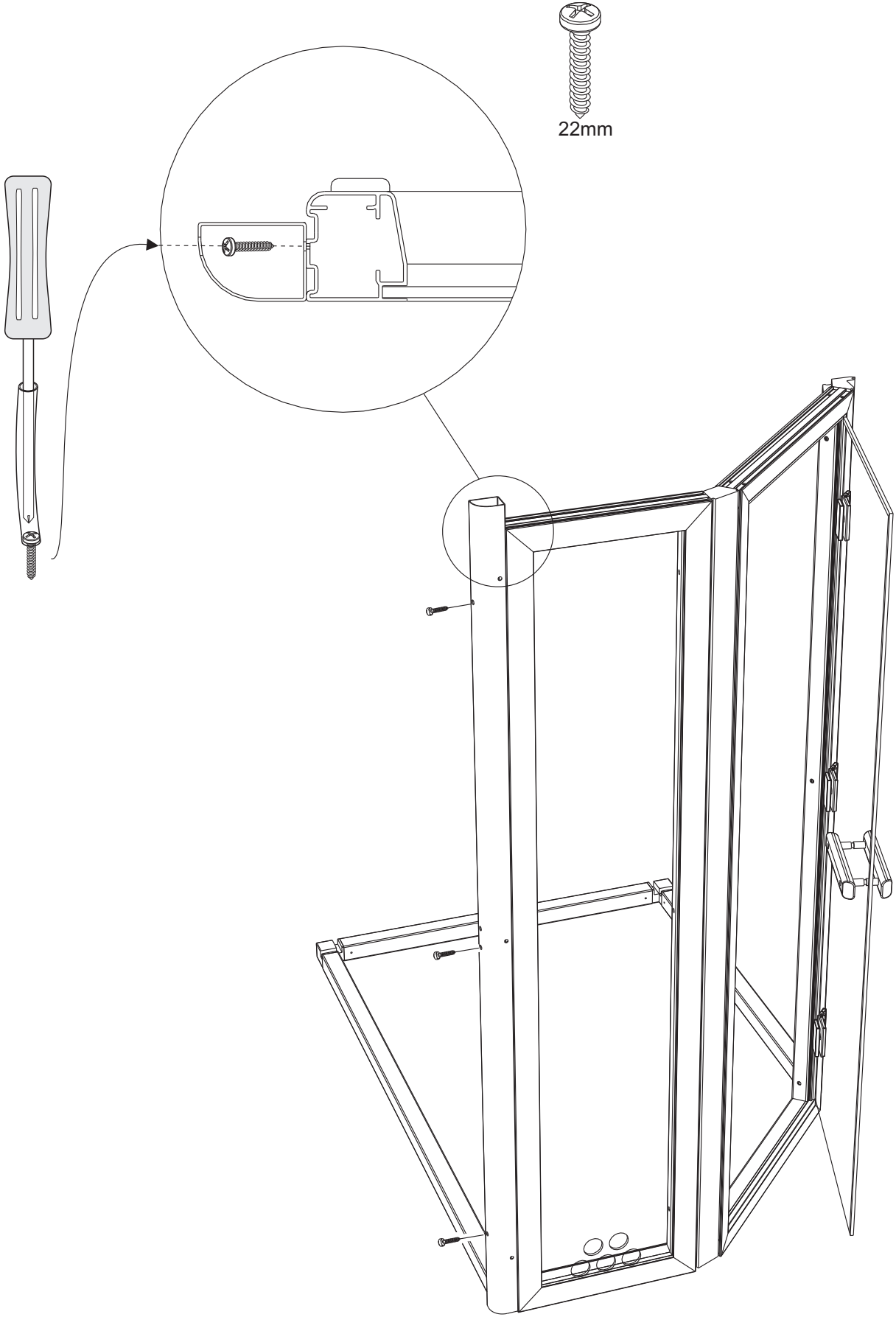

9

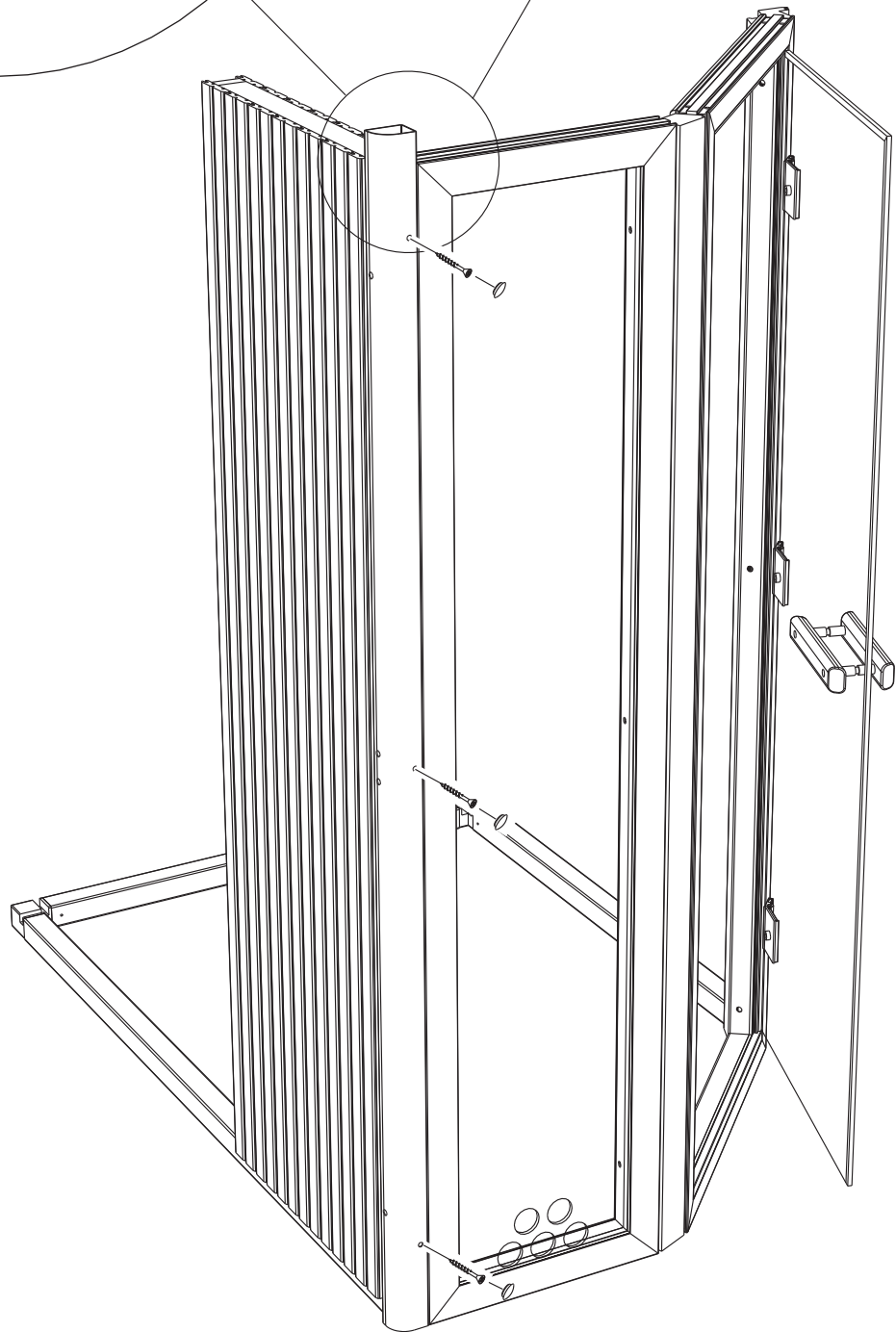
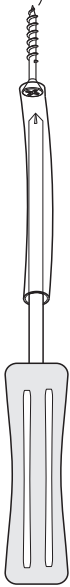
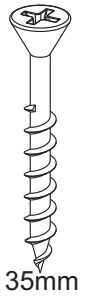
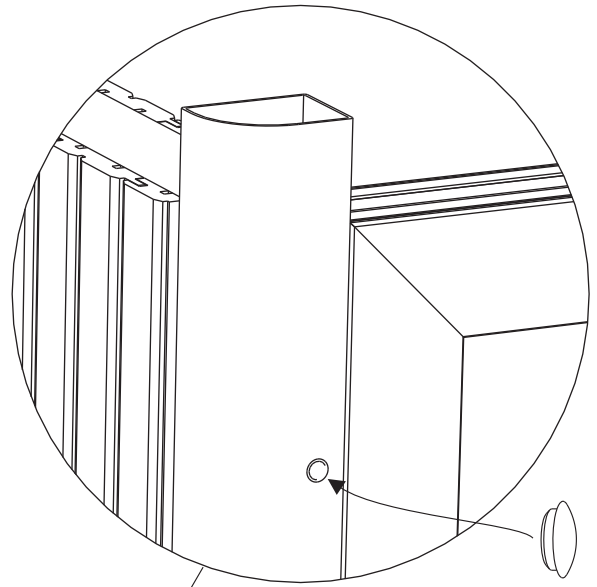
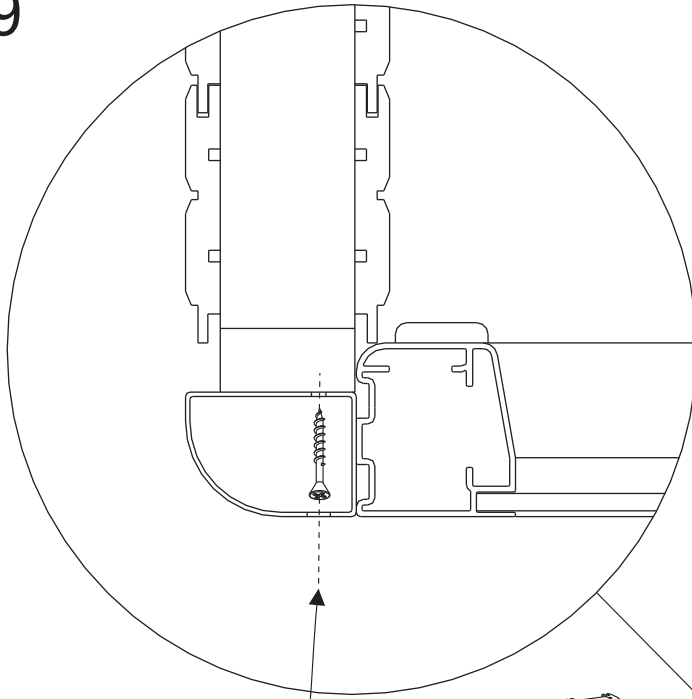

10

Slå försiktigt in sektionen ordentligt på plats, använd en träklot under hammaren så undviker du skador på spanten.

The sections interlock to fit snugly as shown. Tap each section gently into place, hammering against a block of wood to avoid damaging the section.

Durch vorsichtiges Schlagen die Sektion in die richtige Lage bringen. Holzklötz verwenden, um Nut und Feder nicht zu beschädigen.

Emboîtez les panneaux avec précaution à petits coups de marteau en intercalant une cale en bois afin de ne pas endommager la rainure.

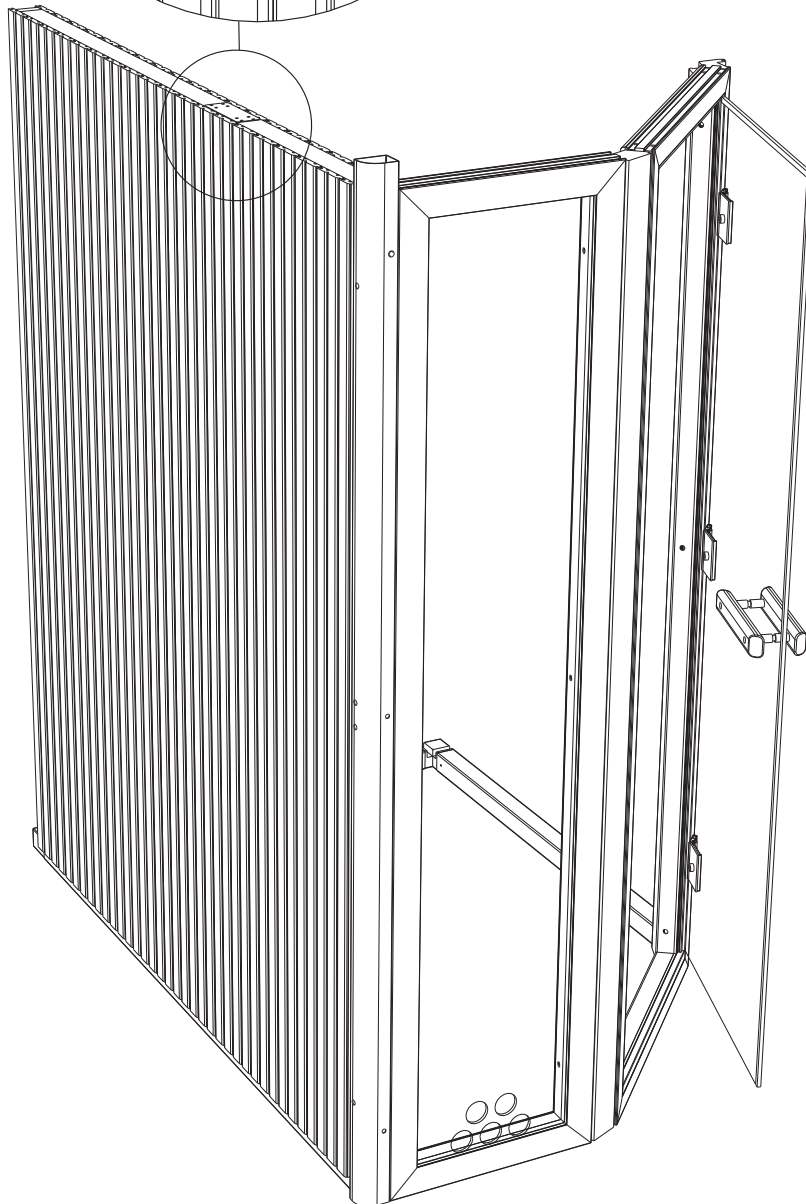
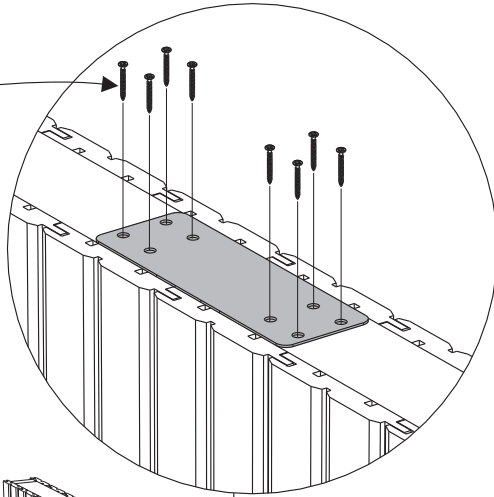
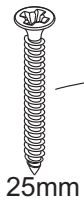
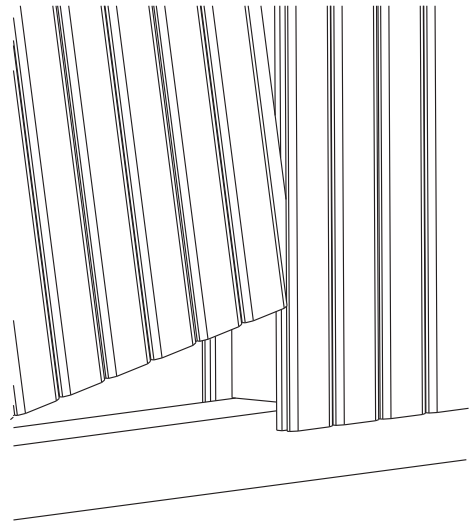

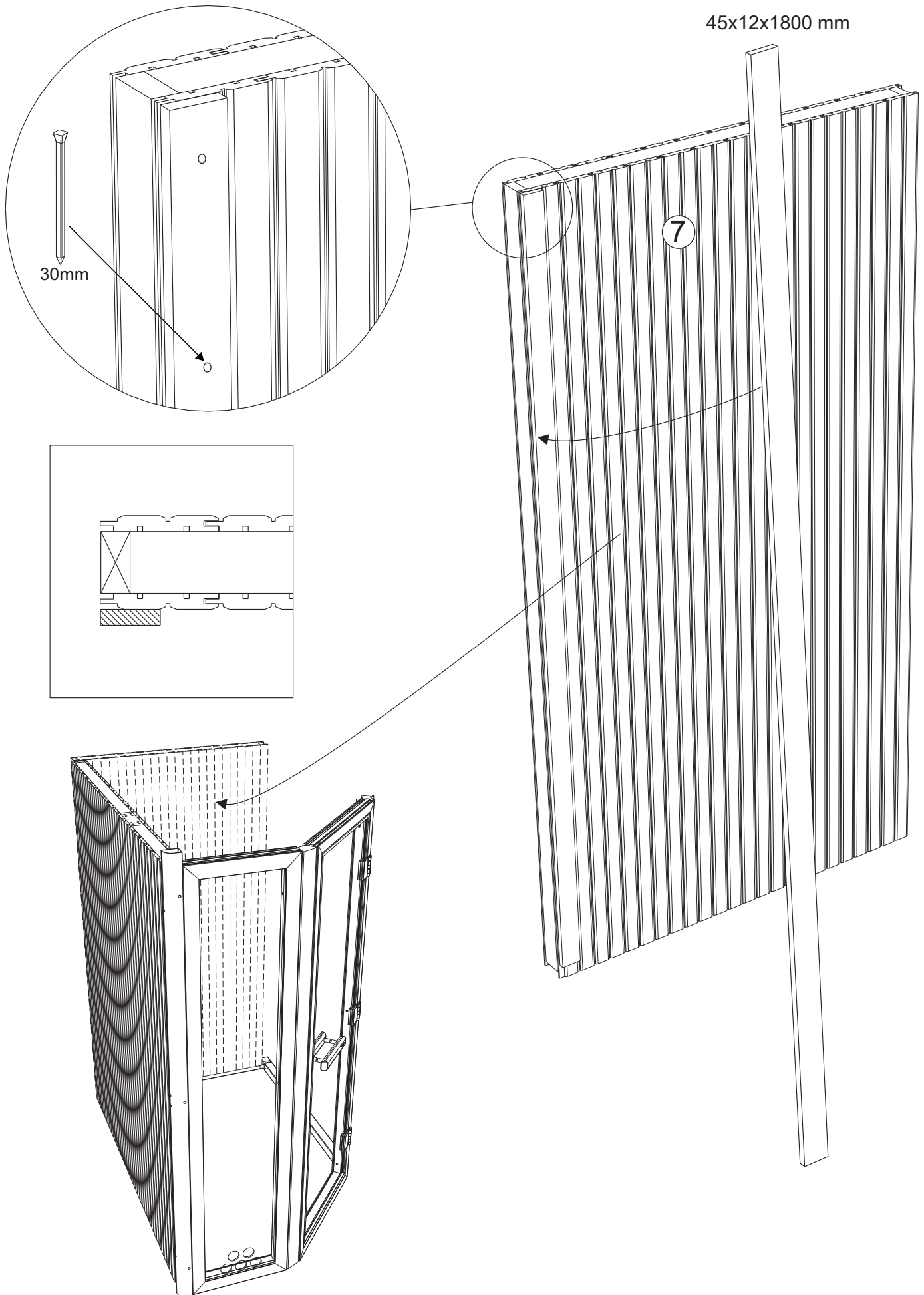

12

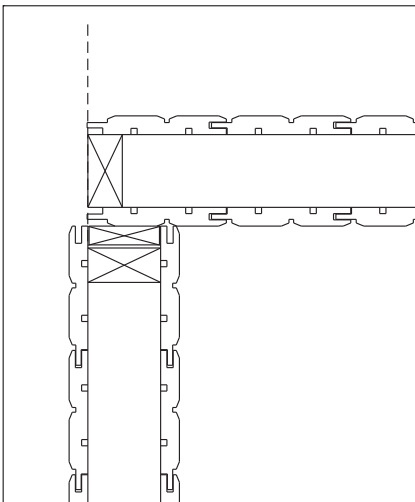
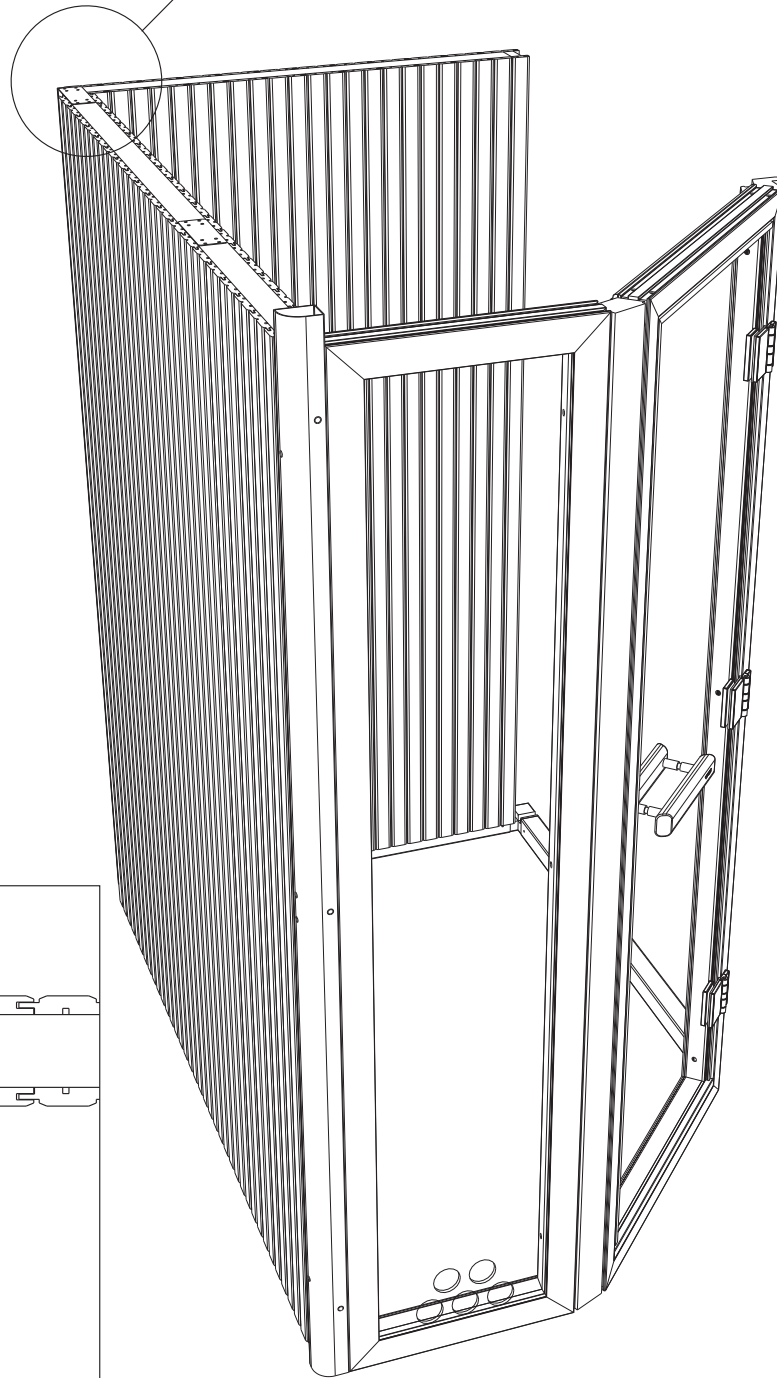
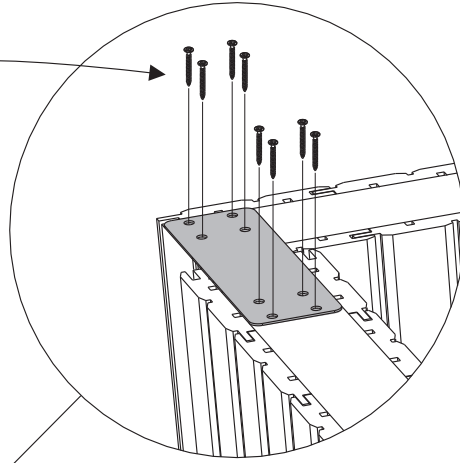
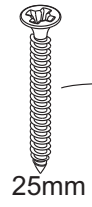

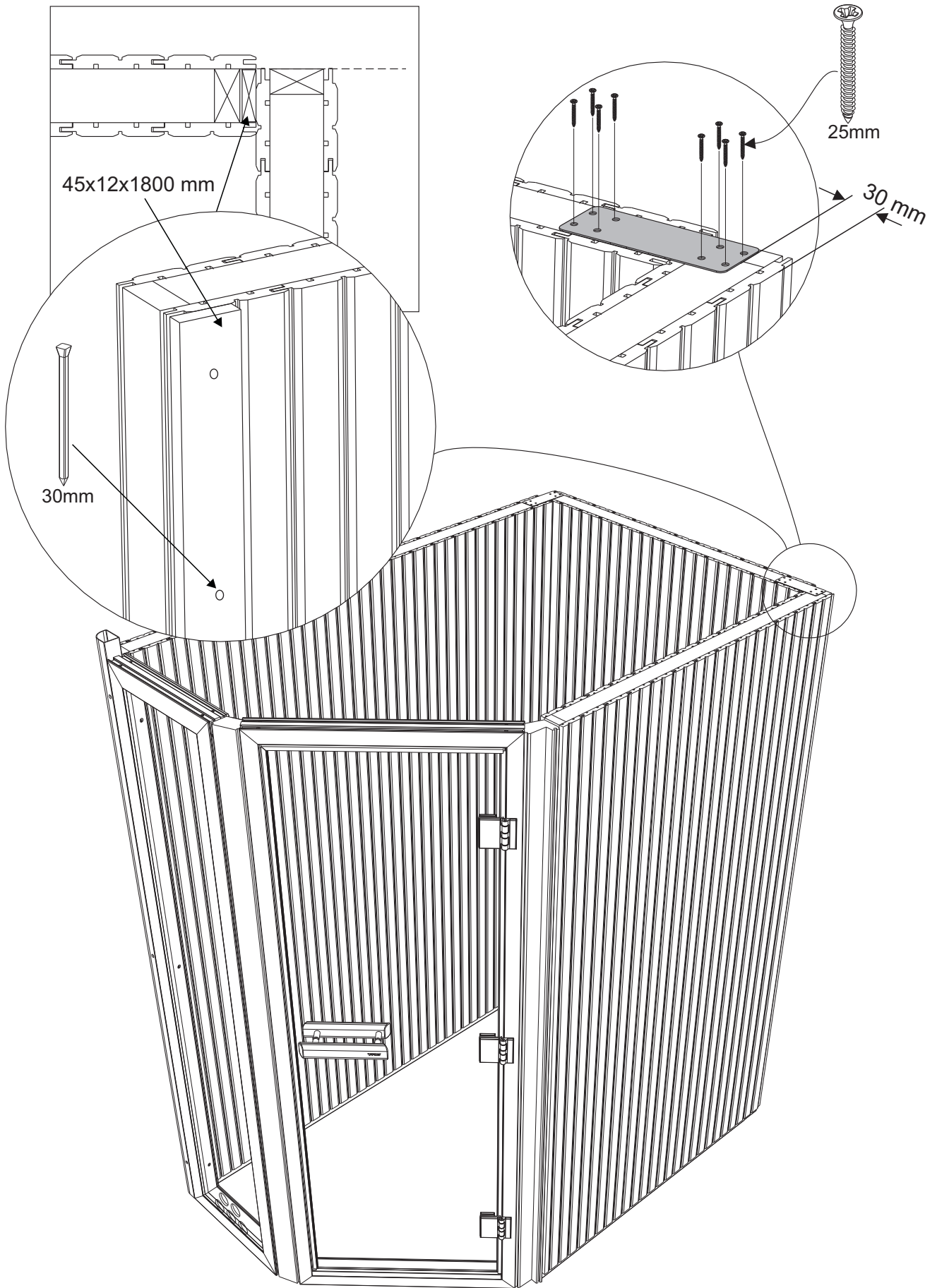

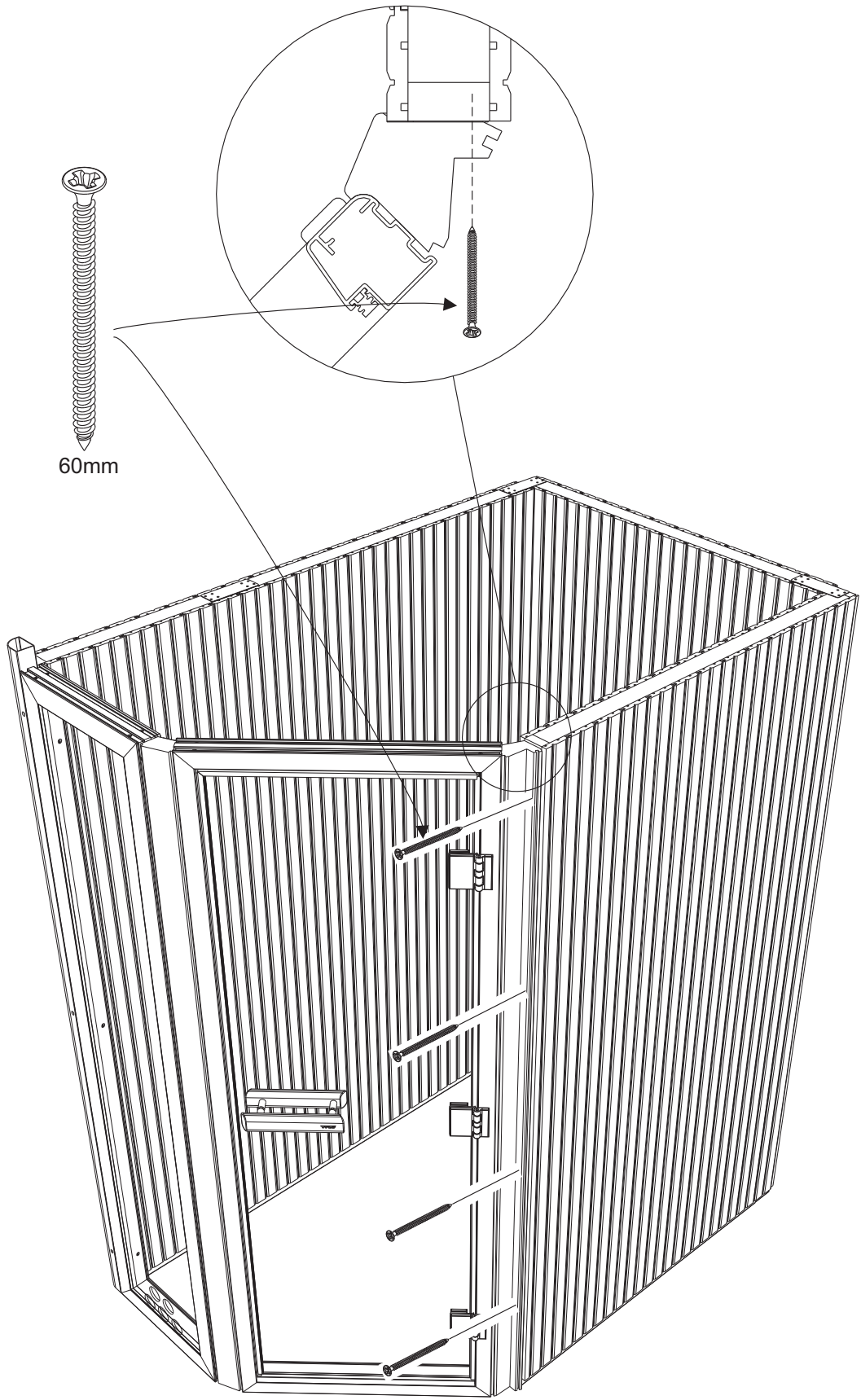

15

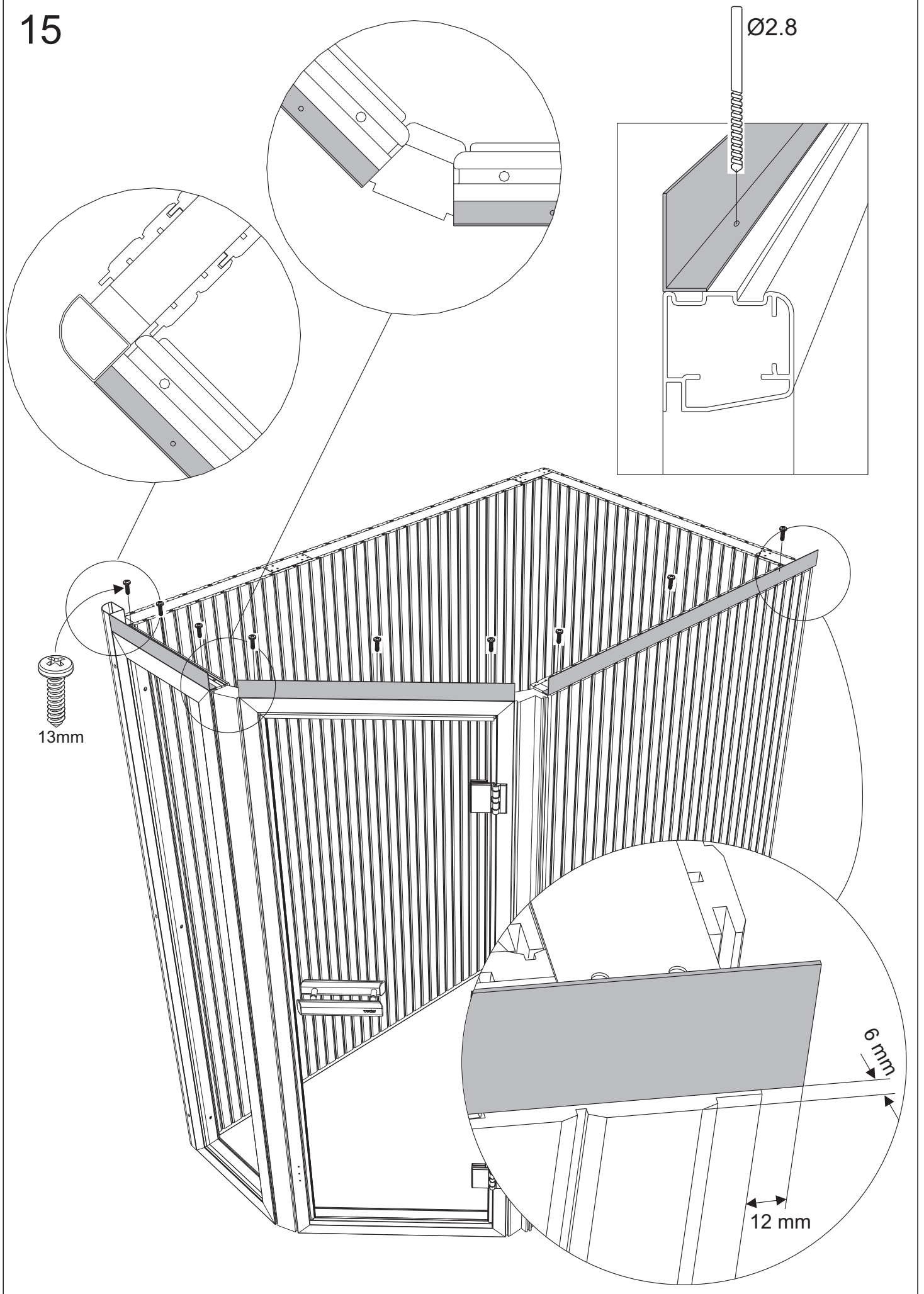

16

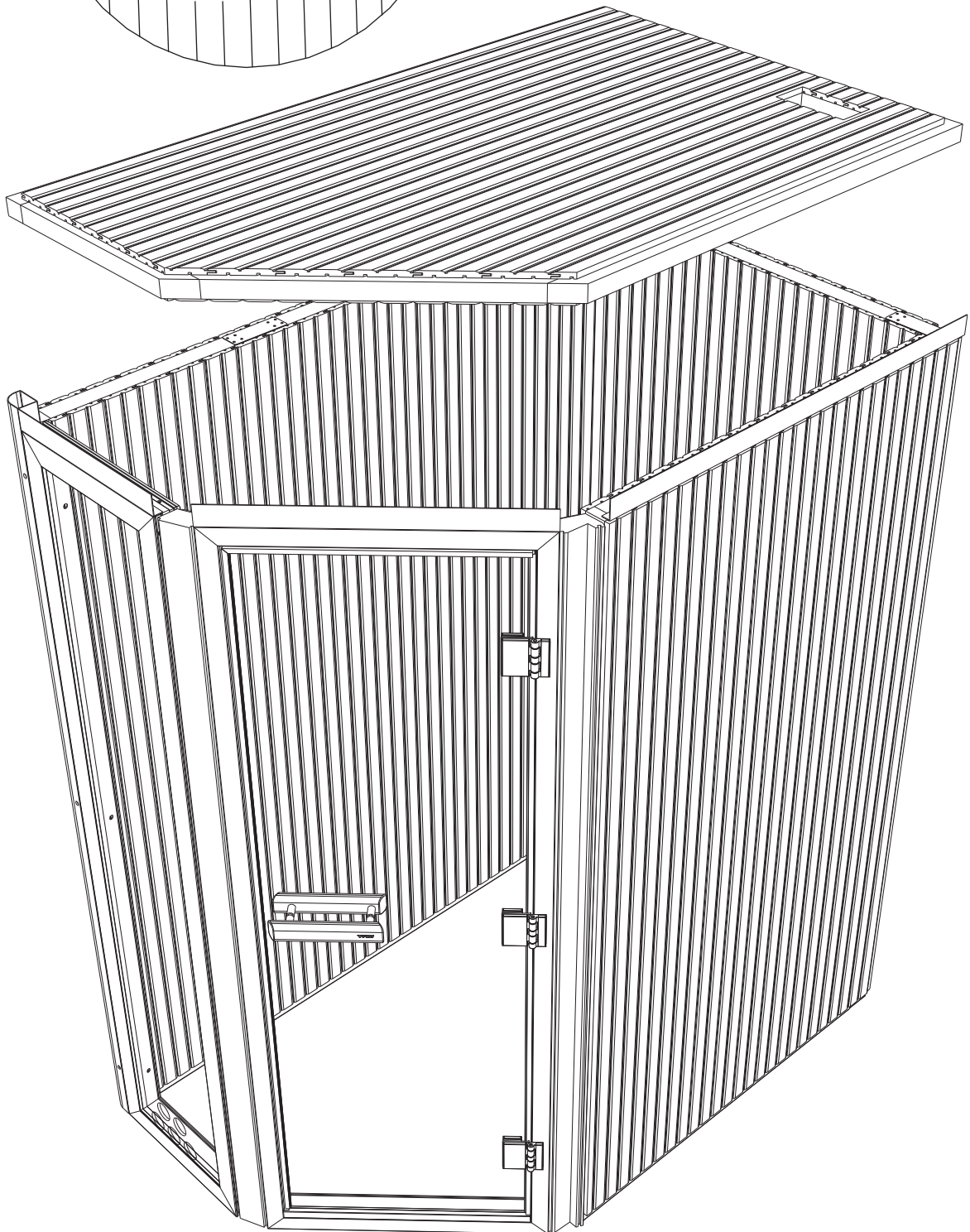
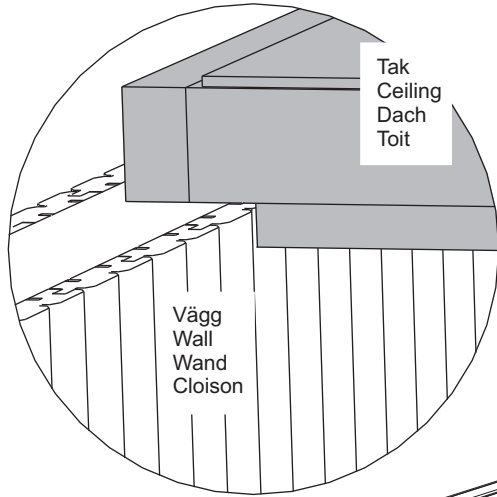

17

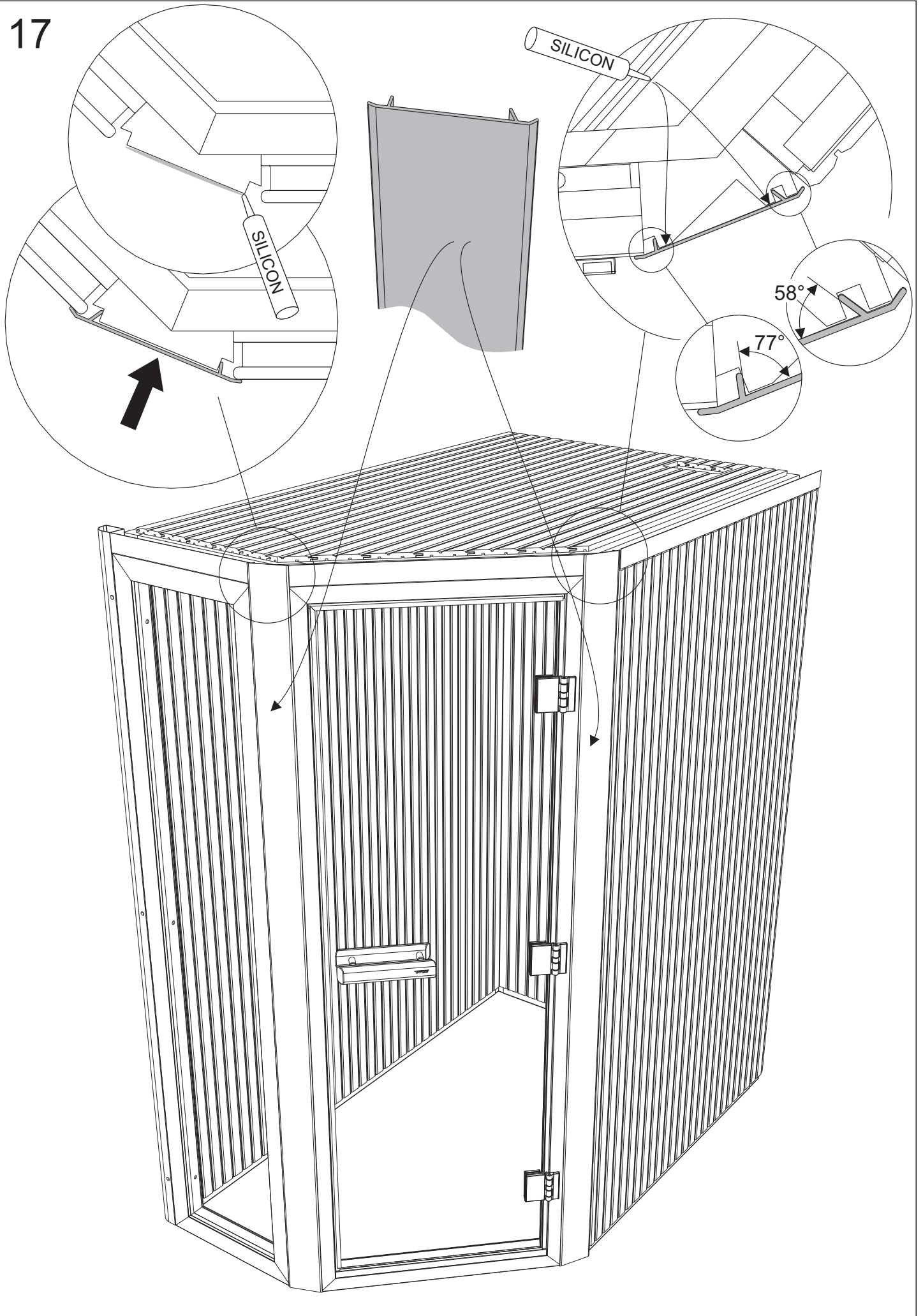

18

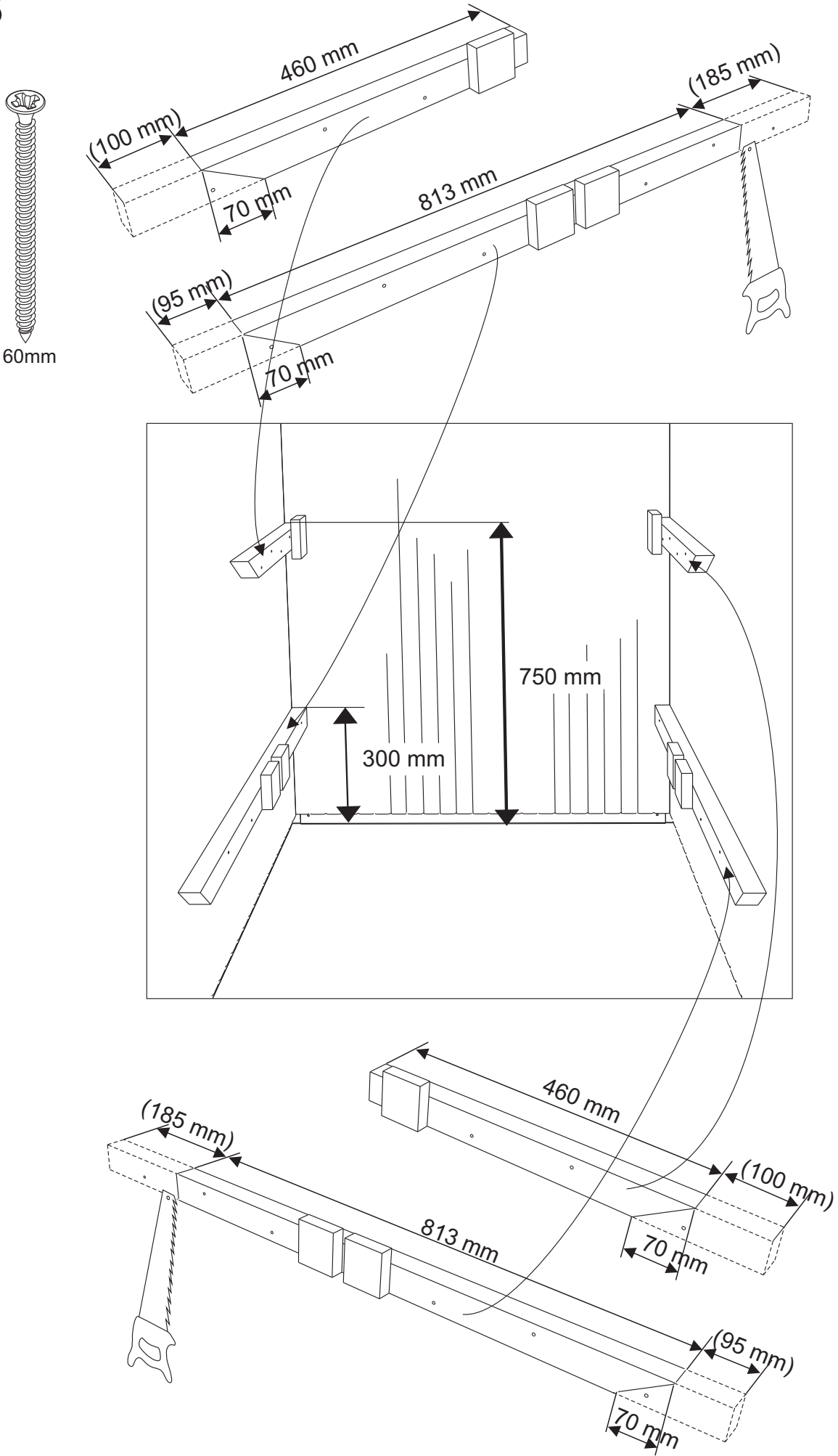

19

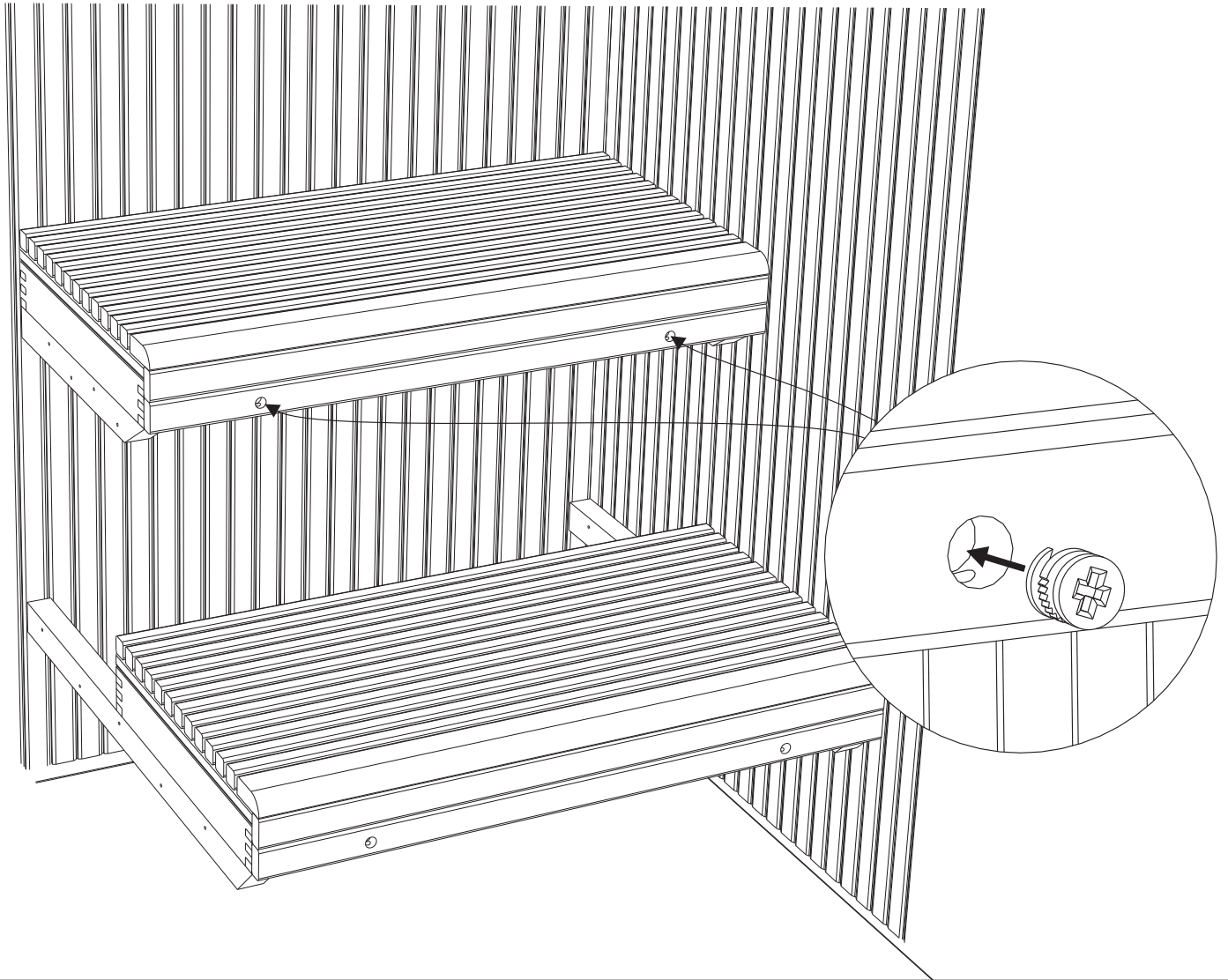

20

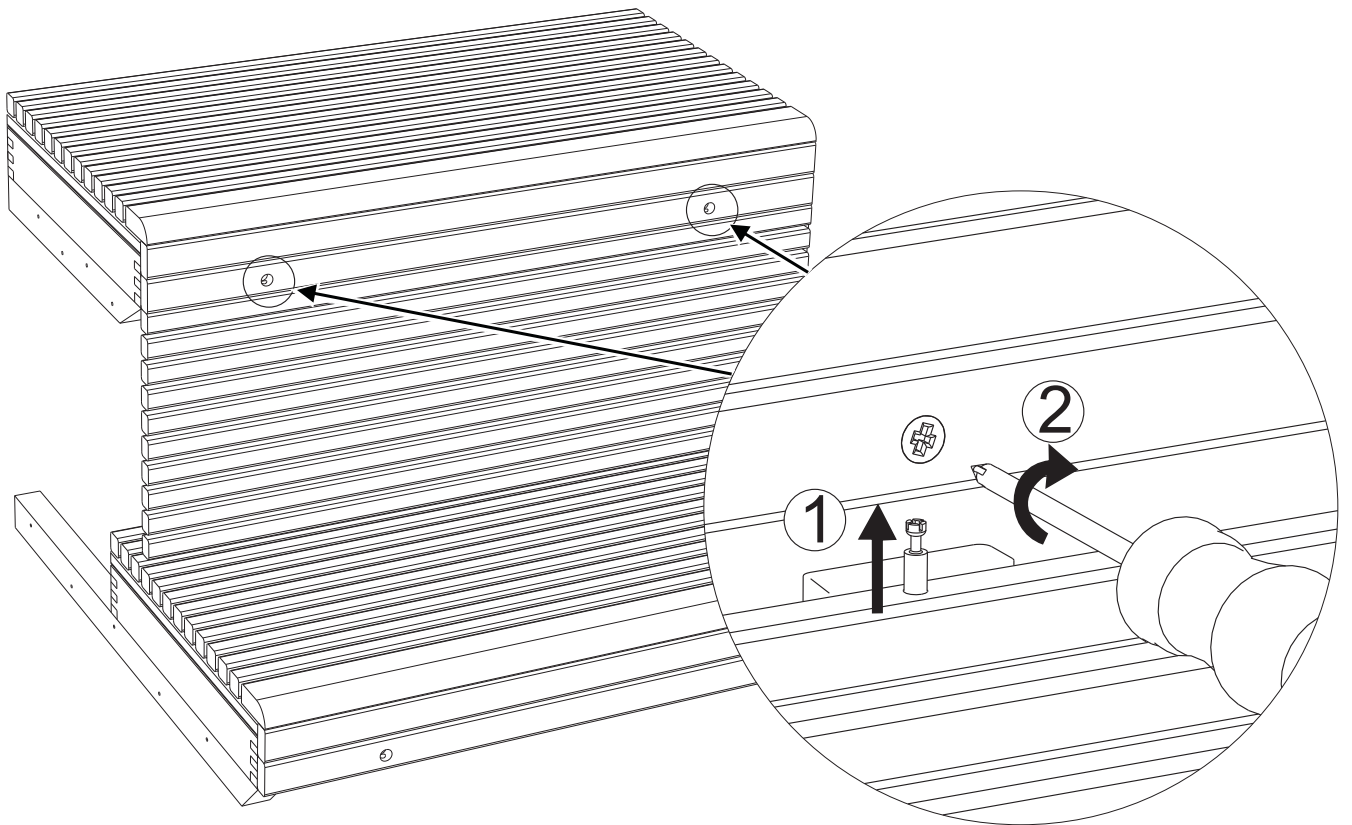

21

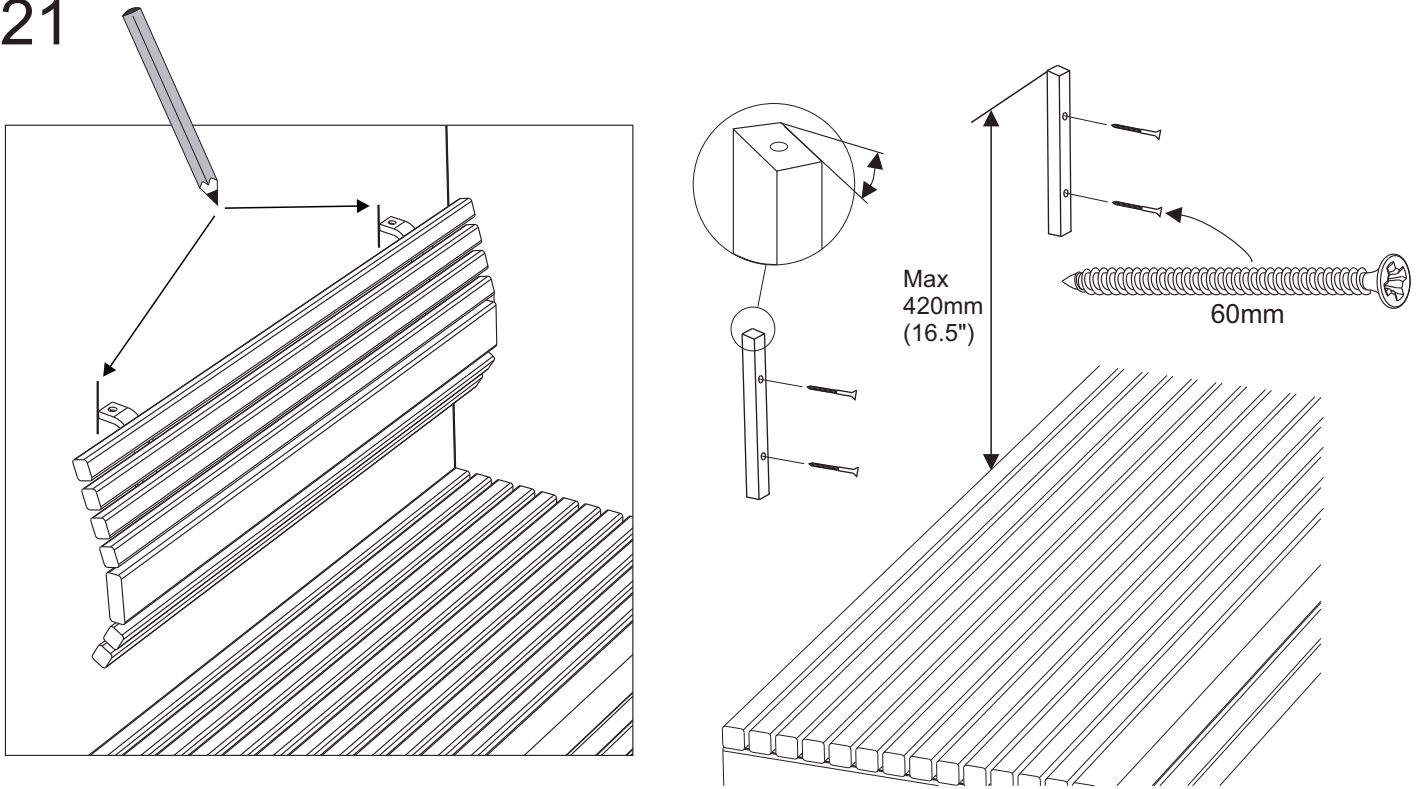

22

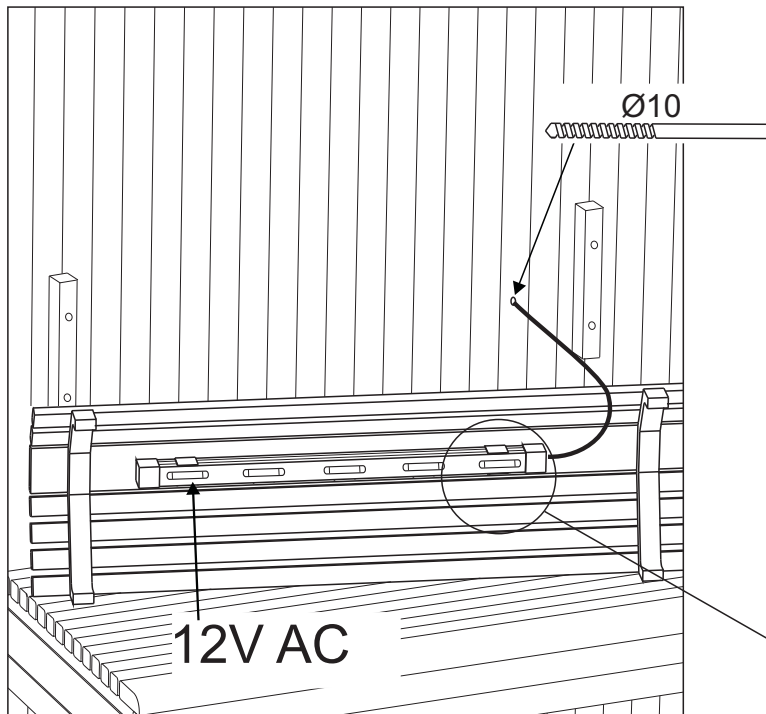

WARNING! Installera ej transformern inne i basturummet.
WARNING! Do not install light transformer inside the sauna room.

WARNUNG! Transformator nicht in dem Saunaraum installieren.

RECOMMANDATIONS! Ne pas installer le transformateur a l'interieur de la cabine sauna.

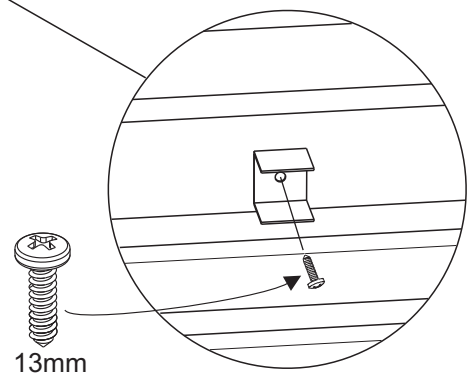

23

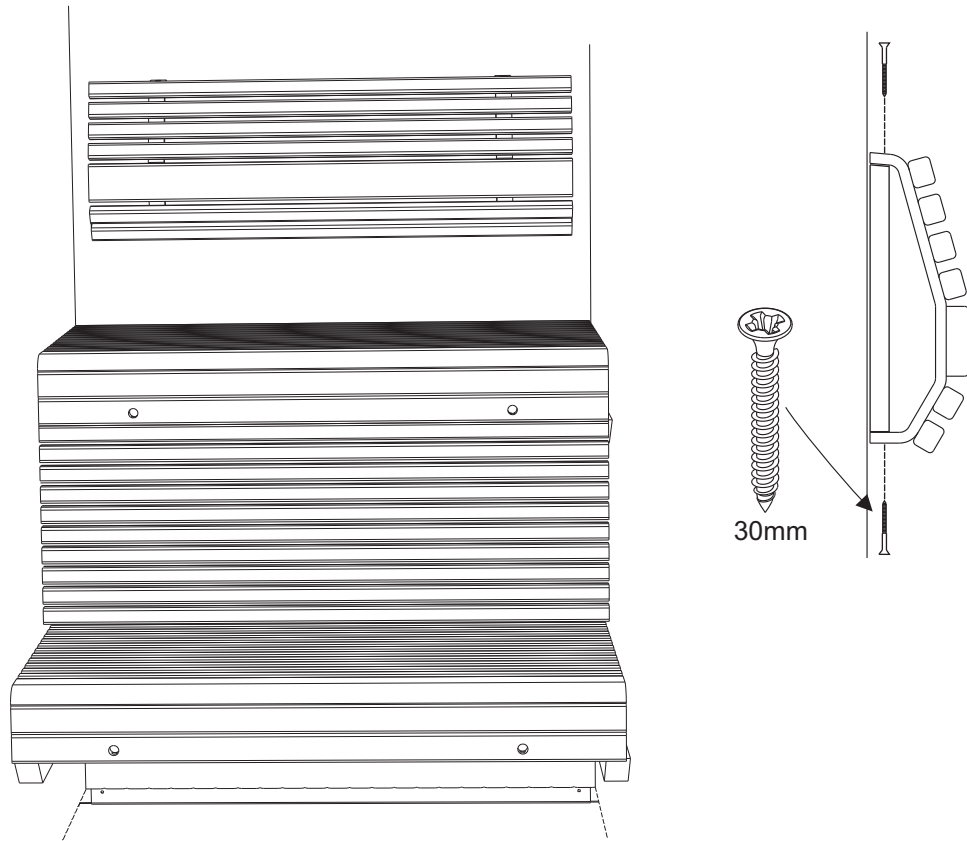

24

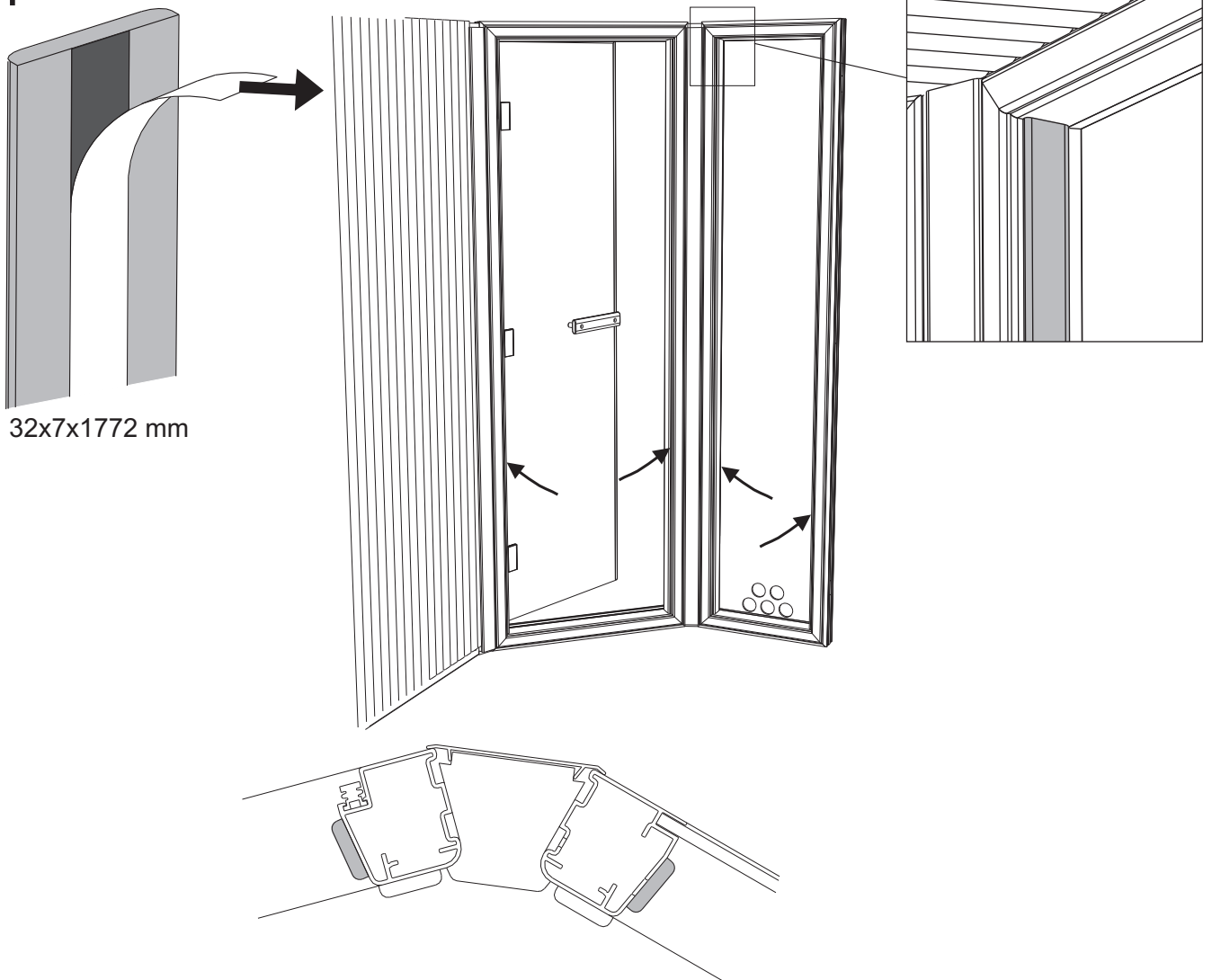

25

X (mm)	kW
620	2.2-4.5
720	6.6

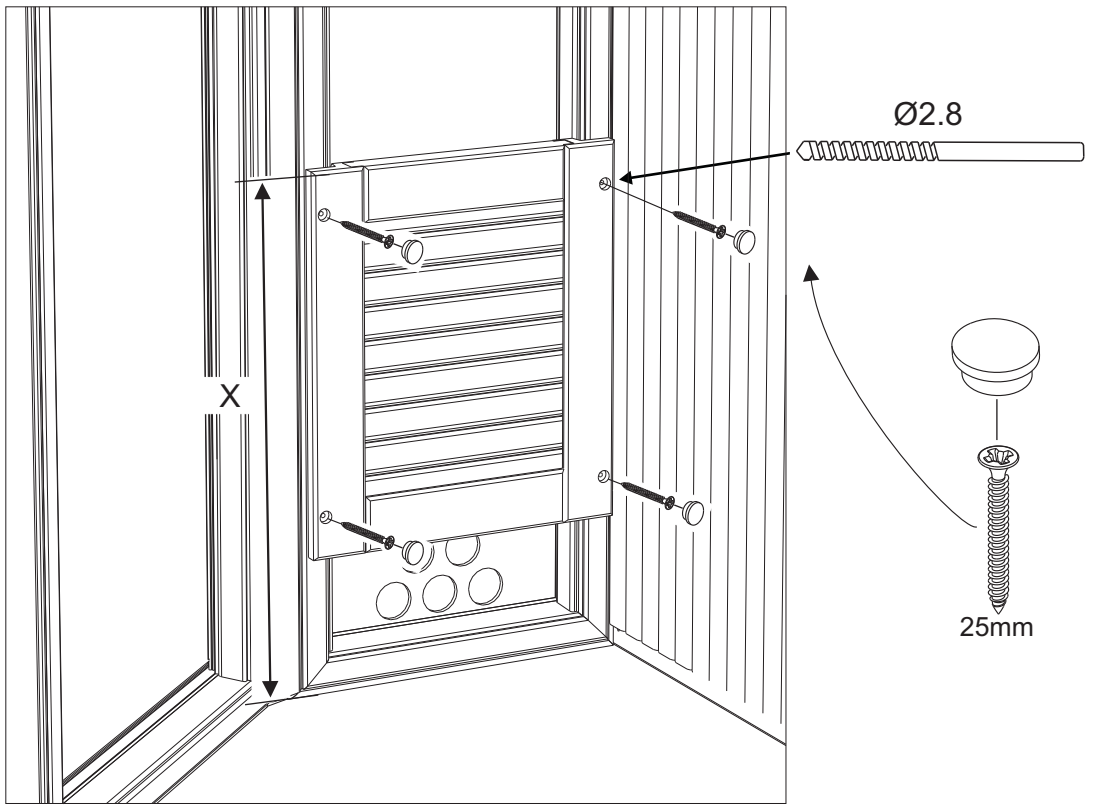

26

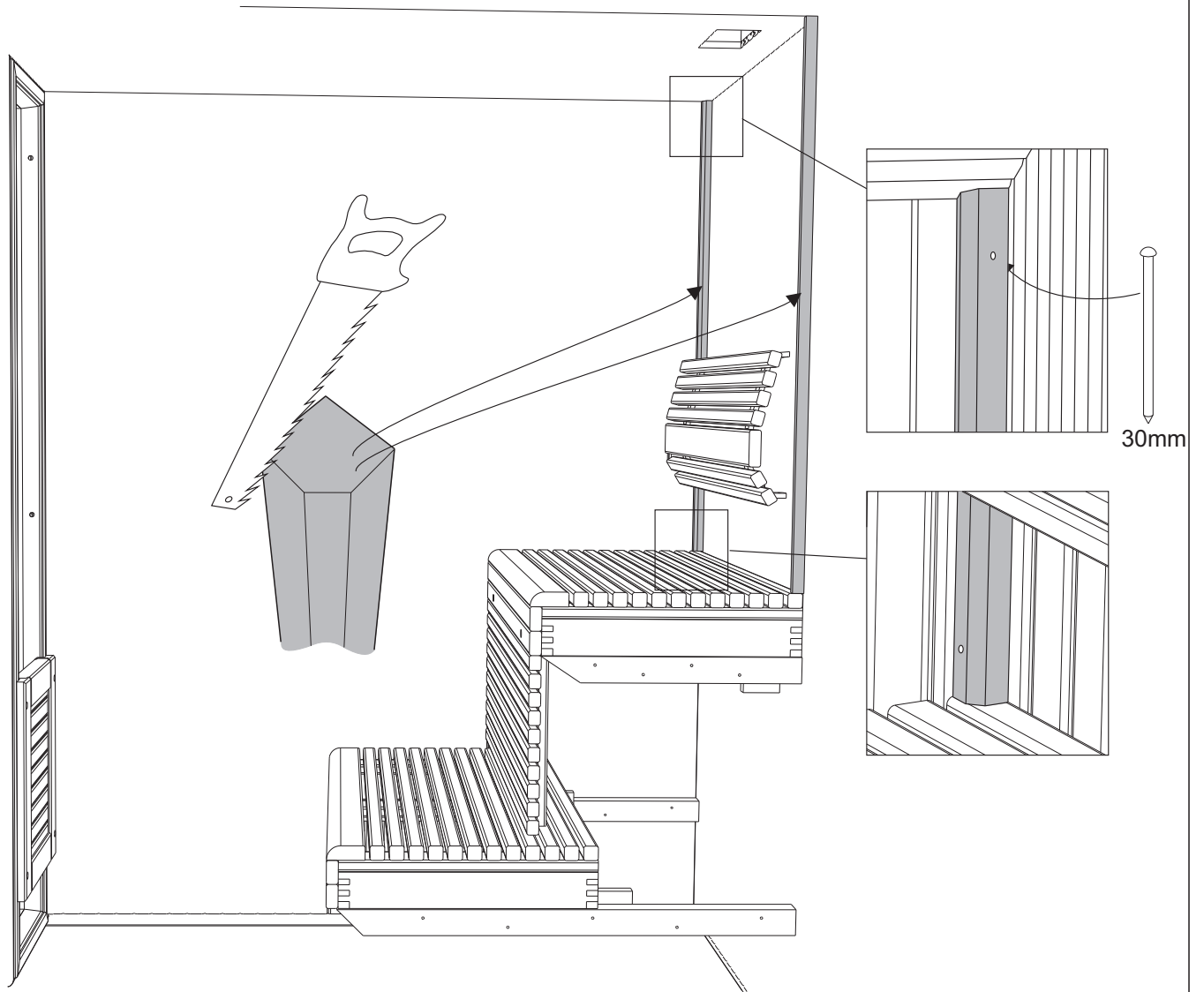

27

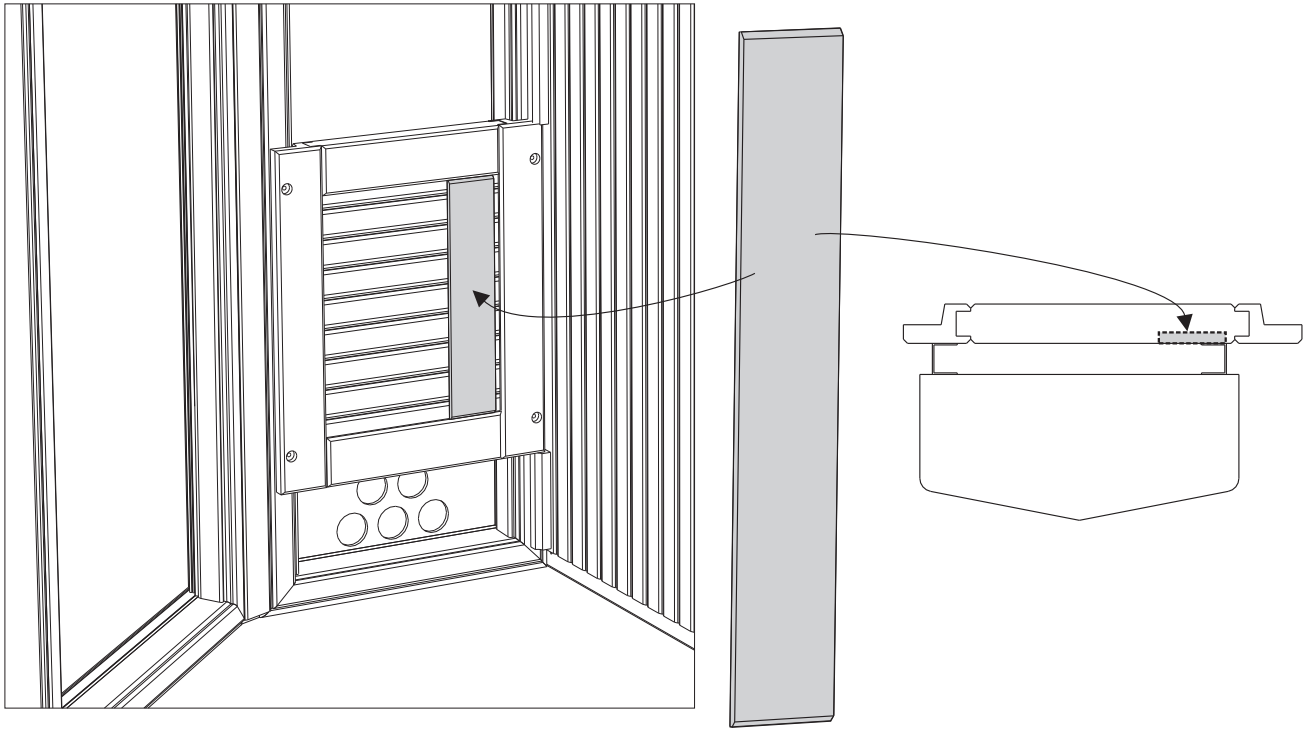

28

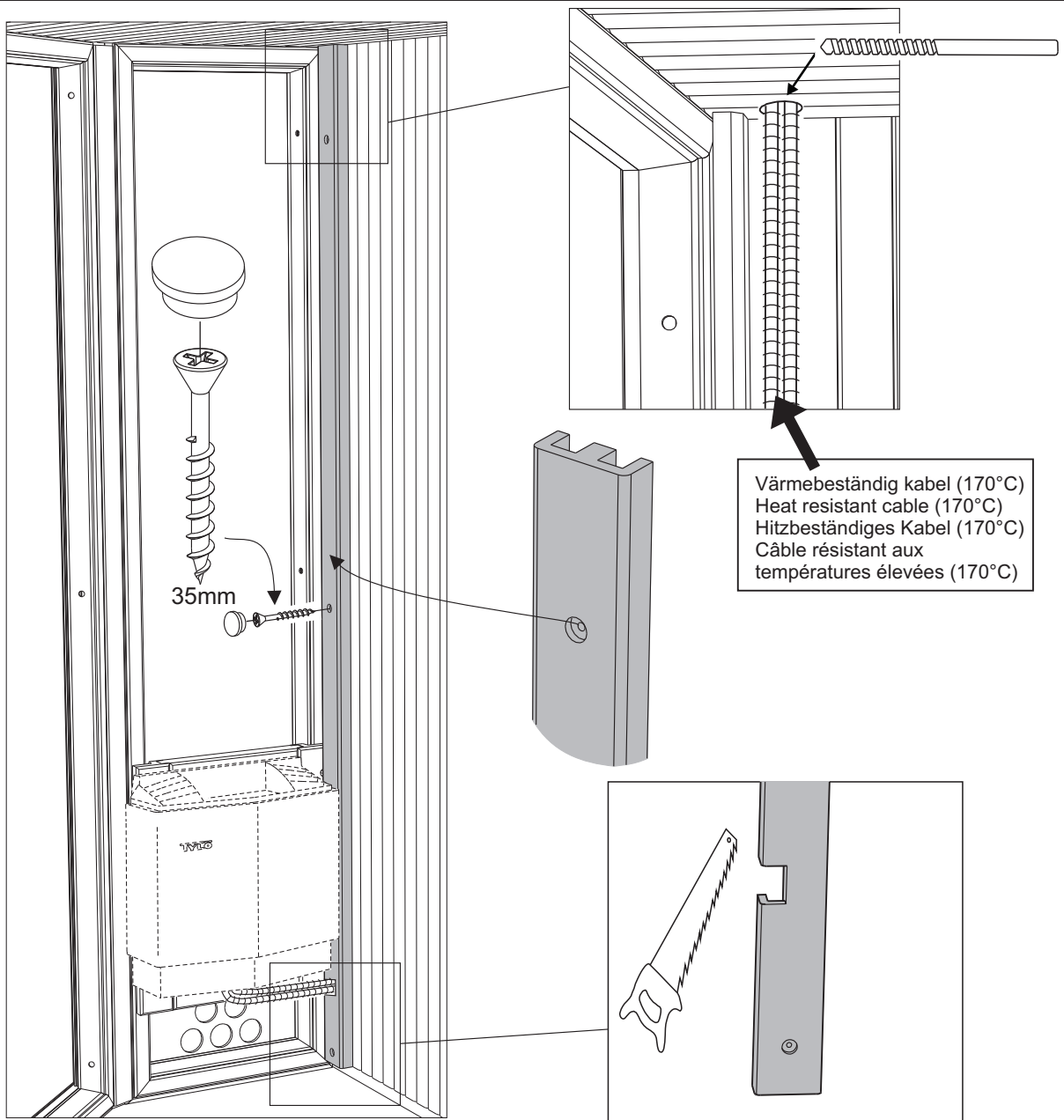

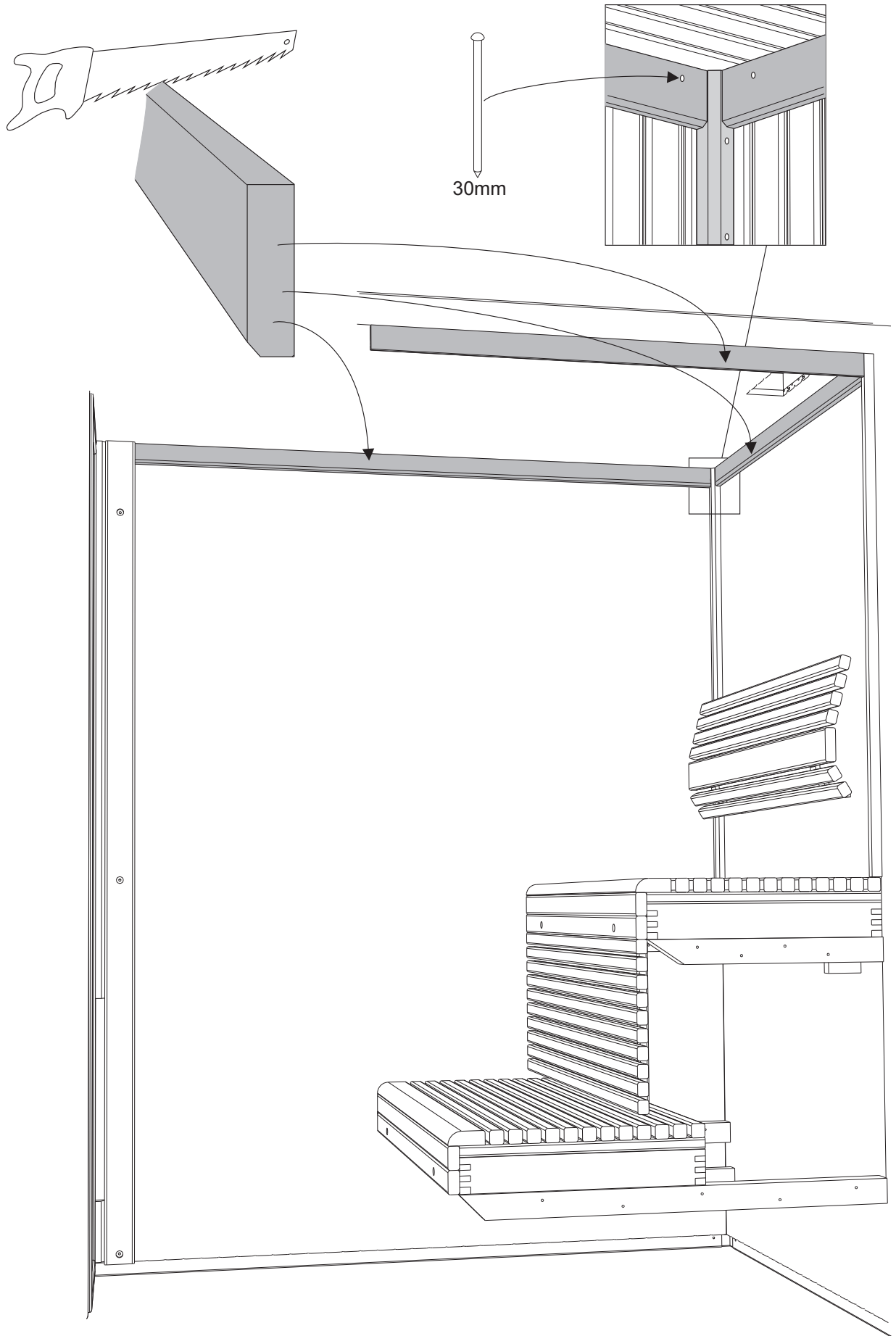

30

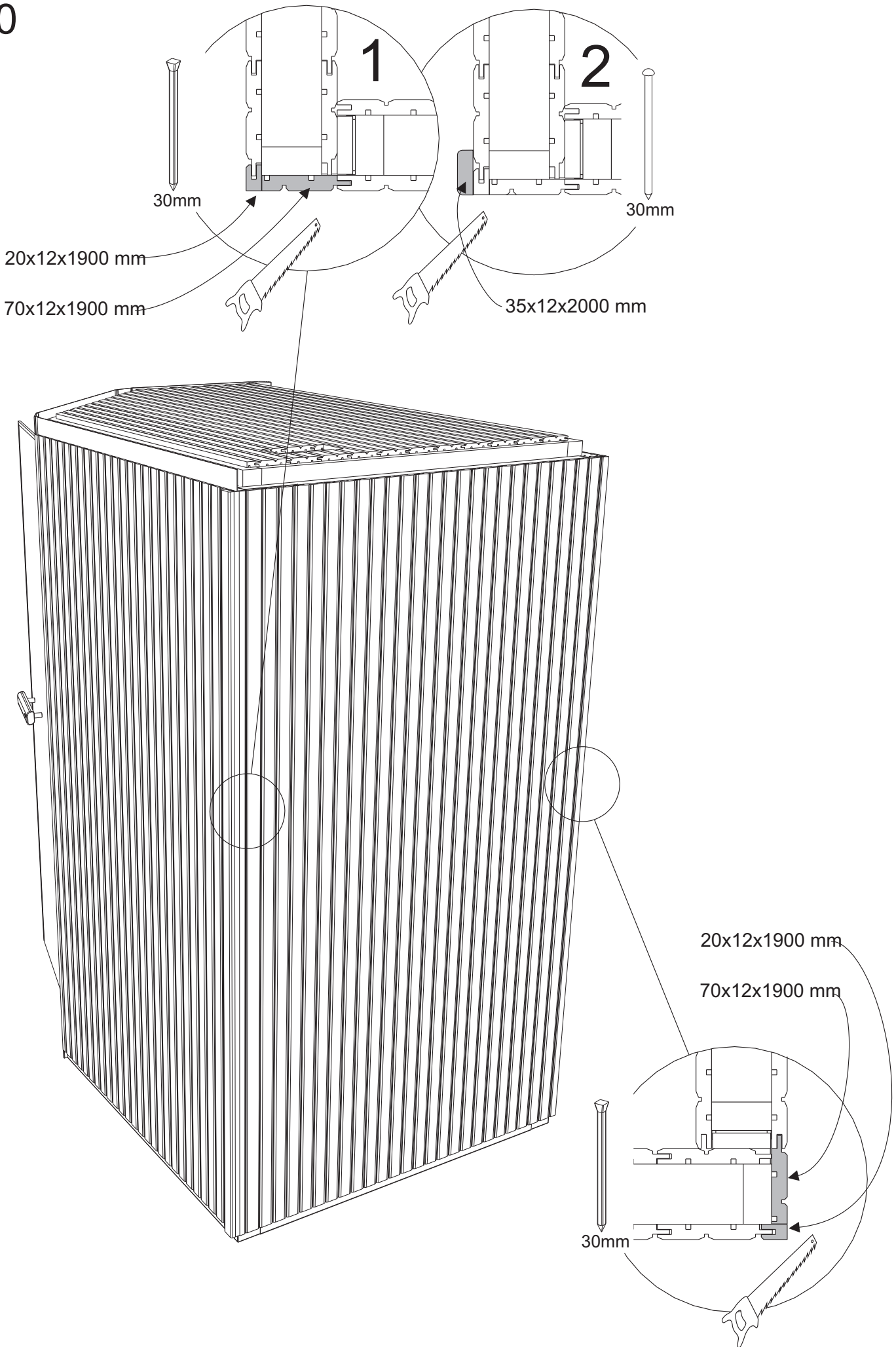

31

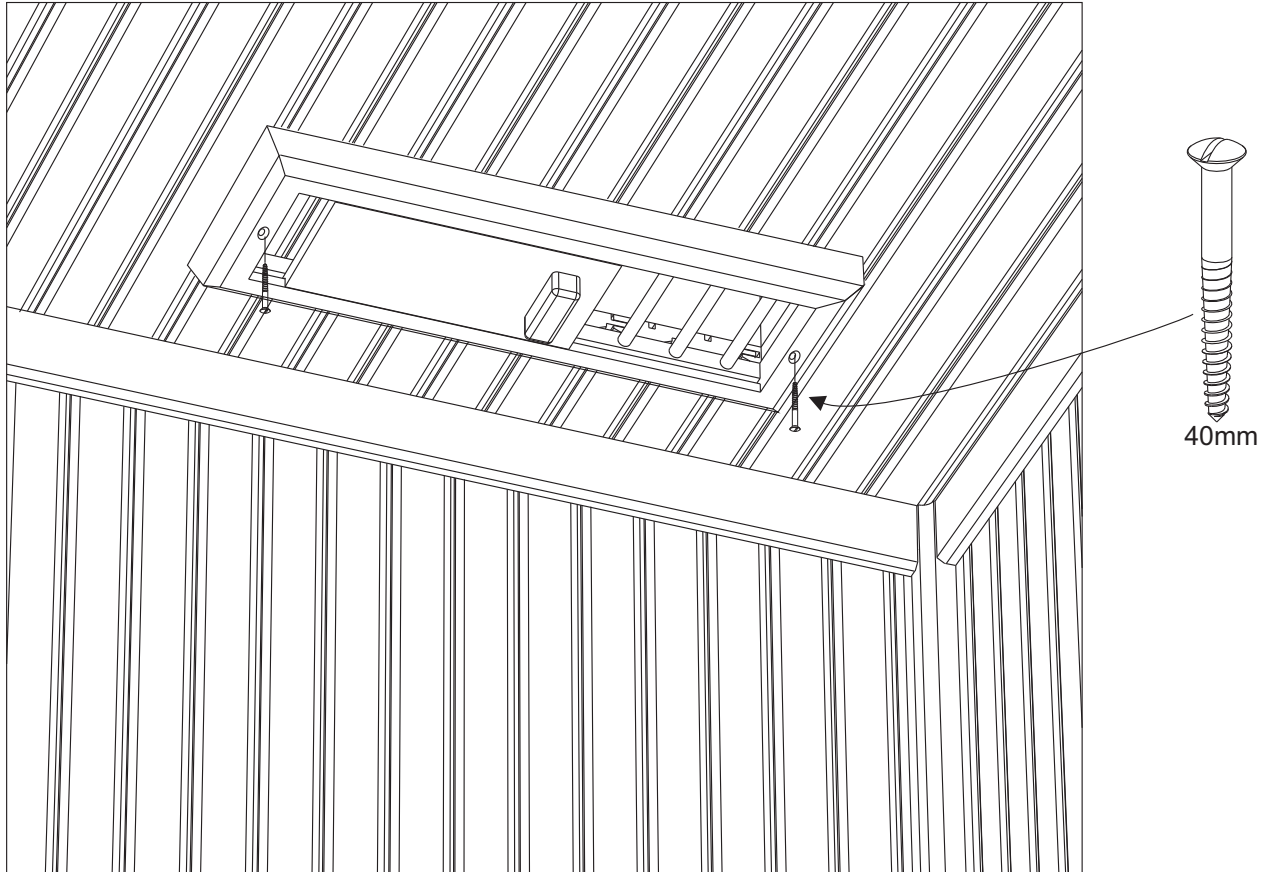

Vid eventuella problem kontakta inköpsstället.

In the event of any problems, please contact the retailer where you purchased the equipment.

Bei eventuellen Störungen setzen Sie sich bitte mit Ihrem Händler in Verbindung.

En cas de problèmes éventuels, prière de s'adresser au point de vente.